

Please check the examination details below before entering your candidate information

Candidate surname

Other names

Centre Number

Candidate Number

Pearson Edexcel Level 1/Level 2 GCSE (9–1)

Wednesday 7 June 2023

Morning (Time: 1 hour 30 minutes)

Paper
reference

1MA1/2H

Mathematics

PAPER 2 (Calculator)
Higher Tier



You must have: Ruler graduated in centimetres and millimetres, protractor, pair of compasses, pen, HB pencil, eraser, calculator, Formulae Sheet (enclosed). Tracing paper may be used.

Total Marks

Instructions

- Use **black** ink or ball-point pen.
- **Fill in the boxes** at the top of this page with your name, centre number and candidate number.
- Answer **all** questions.
- Answer the questions in the spaces provided
– *there may be more space than you need.*
- You must **show all your working**.
- Diagrams are **NOT** accurately drawn, unless otherwise indicated.
- **Calculators may be used.**
- If your calculator does not have a π button, take the value of π to be 3.142 unless the question instructs otherwise.

Information

- The total mark for this paper is 80
- The marks for **each** question are shown in brackets
– *use this as a guide as to how much time to spend on each question.*

Advice

- Read each question carefully before you start to answer it.
- Try to answer every question.
- Check your answers if you have time at the end.

Turn over ►

P75150A

©2023 Pearson Education Ltd.
N:1/1/1/1/1/1/



P 7 5 1 5 0 A 0 1 2 8



Pearson

Answer ALL questions.

Write your answers in the spaces provided.

You must write down all the stages in your working.

1 (a) Work out the value of $\frac{25 - \sqrt{43.87}}{6 + 2.1^2}$

Write down all the figures on your calculator display.

1.76527923

(2)

(b) Work out the value of the reciprocal of 0.625

$$\frac{1}{0.625} = \frac{8}{5} \text{ or } 1.6$$

1.6

(1)

(Total for Question 1 is 3 marks)

DO NOT WRITE IN THIS AREA

DO NOT WRITE IN THIS AREA

DO NOT WRITE IN THIS AREA



2 Write 60 as a product of its prime factors.

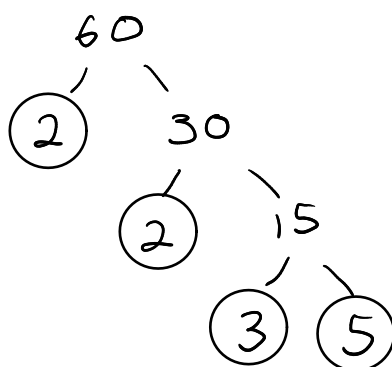

$$2 \times 2 \times 3 \times 5$$

(Total for Question 2 is 2 marks)

3 There are 48 counters in a bag.
There are only red counters and blue counters in the bag.

$$\text{number of red counters} : \text{number of blue counters} = 1 : 2$$

Helen has to work out how many red counters are in the bag.

She says,

“There are 24 red counters in the bag because 1 is half of 2 and 24 is half of 48”

Is Helen correct?

You must give a reason for your answer.

No. $\frac{1}{3}$ of the counters are red not $\frac{1}{2}$

(Total for Question 3 is 1 mark)



4 $-2 \leq n < 5$

n is an integer.

(a) Write down the greatest possible value of n .

4
(1)

(b) On the number line below, show the inequality $-4 \leq m < 1$

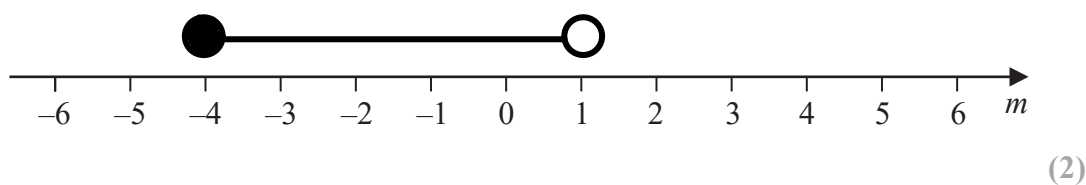

(c) Solve $\frac{2}{5}g - 4 < 6$

$$\frac{2}{5}g < 10$$

$$2g < 50$$

$$g < 25$$

$g < 25$
(3)

(Total for Question 4 is 6 marks)



5 Here is a triangle and a rectangle.

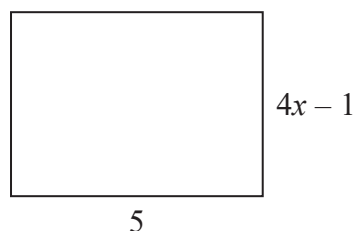
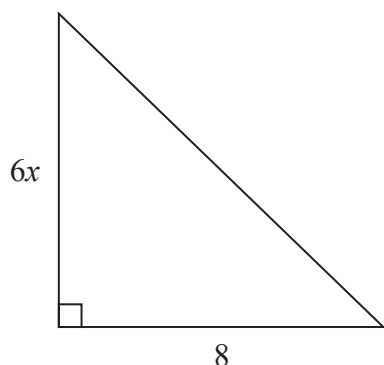

All measurements are in centimetres.

The area of the triangle is 10 cm^2 greater than the area of the rectangle.

Work out the value of x .

Triangle :

$$\begin{aligned} \text{Area} &= \frac{1}{2} \times 8 \times 6x \\ &= 4 \times 6x \\ &= \underline{24x} \end{aligned}$$

Rectangle :

$$\begin{aligned} \text{Area} &= 5 \times (4x - 1) \\ &= 5(4x - 1) \\ &= \underline{20x - 5} \end{aligned}$$

$$24x - 10 = 20x - 5$$

$$24x = 20x + 5$$

$$4x = 5$$

$$x = \frac{5}{4}$$

$$= \underline{1.25}$$

$$x = \underline{1.25}$$

(Total for Question 5 is 4 marks)



- 6 Last year a family recycled 800 kg of household waste.
57% of this waste was paper and glass.

$$\text{weight of paper recycled : weight of glass recycled} = 12:7 \quad 19 \text{ parts}$$

Calculate the weight of glass the family recycled.

$$0.57 \times 800 = 456$$

$$\frac{456}{19} = 24 \quad (\text{each part is } 24 \text{ kg})$$

$$7 \times 24 = \underline{\underline{168}} \text{ kg}$$

..... 168 kg

(Total for Question 6 is 3 marks)

DO NOT WRITE IN THIS AREA

DO NOT WRITE IN THIS AREA

DO NOT WRITE IN THIS AREA



- 7 A number, d , is rounded to 1 decimal place.
The result is 12.7

Complete the error interval for d .

$$12.65 \leq d < 12.75$$

(Total for Question 7 is 2 marks)

- 8 Tamsin buys a house with a value of £150 000
The value of Tamsin's house increases by 4% each year.

Rachel buys a house with a value of £160 000
The value of Rachel's house increases by 1.5% each year.

At the end of 2 years, whose house has the greater value?
You must show how you get your answer.

$$\text{Tamsin : } 150000 \times 1.04^2 = £162240$$

$$\text{Rachel : } 160000 \times 1.015^2 = £164836$$

Rachel's house

(Total for Question 8 is 4 marks)



- 9 The cumulative frequency table gives information about the ages of 80 people working for a company.

| Age (a years) | Cumulative frequency |
|------------------|----------------------|
| $20 < a \leq 30$ | 20 |
| $20 < a \leq 40$ | 48 |
| $20 < a \leq 50$ | 64 |
| $20 < a \leq 60$ | 75 |
| $20 < a \leq 70$ | 80 |

- (a) On the grid opposite, draw a cumulative frequency graph for this information.

(2)

- (b) Use your graph to find an estimate for the median age.

..... 37 years
(1)
(36 to 38)



DO NOT WRITE IN THIS AREA

DO NOT WRITE IN THIS AREA

DO NOT WRITE IN THIS AREA

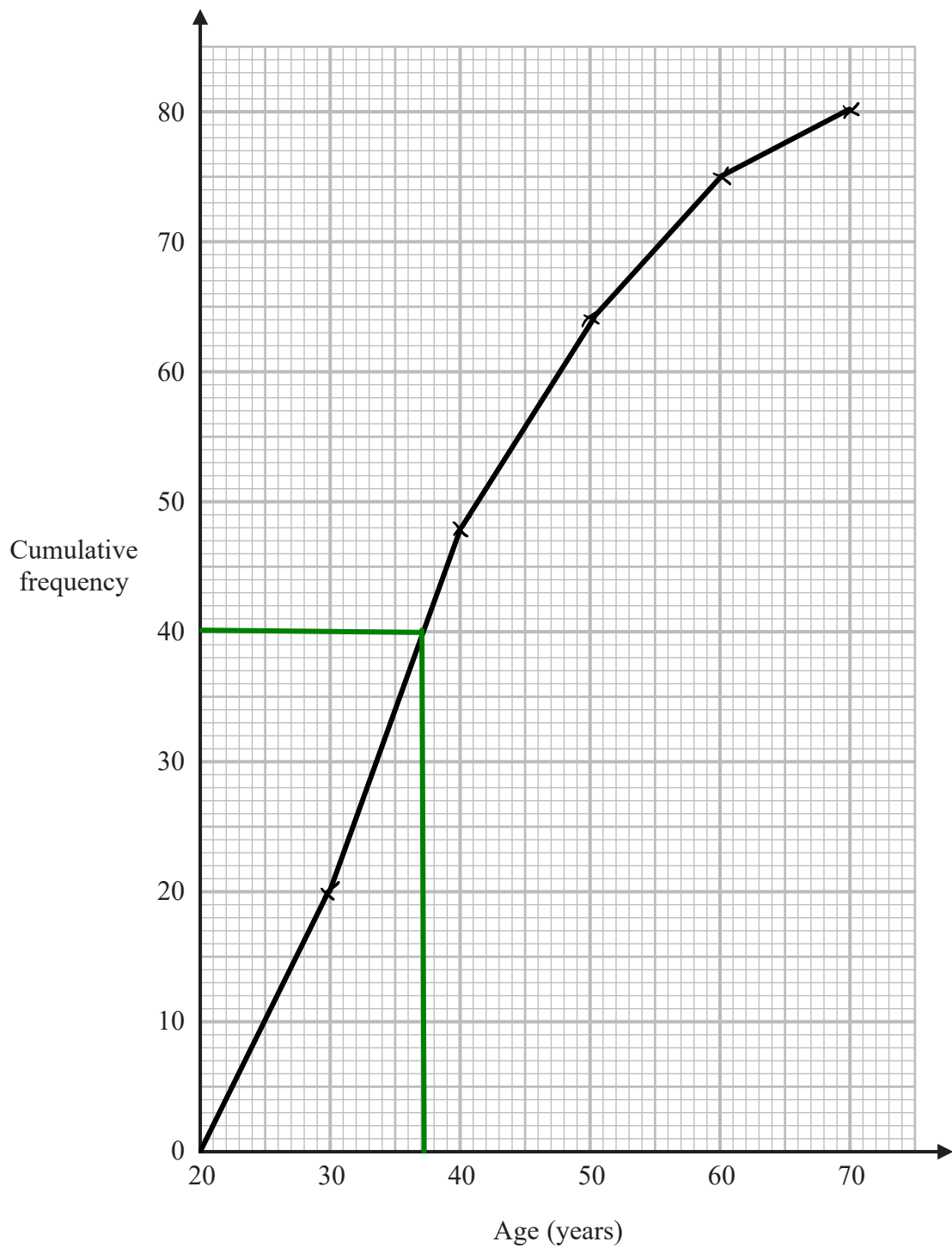

(Total for Question 9 is 3 marks)



10 A biased dice is thrown 60 times.

The table shows information about the number that the dice lands on each time.

| | | | | | | |
|----------------|----|---|---|---|---|----|
| Number on dice | 1 | 2 | 3 | 4 | 5 | 6 |
| Frequency | 12 | 7 | 8 | 9 | 9 | 15 |

Gethin throws the dice twice.

(a) Work out an estimate for the probability that the dice will land on 6 both times.

$$\frac{15}{60} = \frac{1}{4}$$

$$\frac{1}{4} \times \frac{1}{4} = \frac{1}{16}$$

$$\frac{1}{16}$$

(3)

Sally is going to throw the same dice n times and record the number it lands on each time.

She will use her results to work out a more reliable estimate for the probability in part (a).

(b) What can you say about the value of n ?

n must be greater than 60.

(1)

(Total for Question 10 is 4 marks)



11 Use algebra to solve the simultaneous equations

$$\begin{array}{r} 2x + 6y = 5 \quad \times 3 \\ 3x - 4y = -12 \quad \times 2 \end{array}$$

$$\begin{array}{r} 6x + 18y = 15 \\ \underline{\quad} \\ 6x - 8y = -24 \end{array}$$

$$\begin{array}{r} 26y = 39 \\ y = 1.5 \end{array}$$

$$2x + 6y = 5$$

$$2x + 6(1.5) = 5$$

$$2x + 9 = 5$$

$$2x = -4$$

$$x = -2$$

$$x = \dots - 2 \dots$$

$$y = \dots 1.5 \dots$$

(Total for Question 11 is 4 marks)

DO NOT WRITE IN THIS AREA

DO NOT WRITE IN THIS AREA

DO NOT WRITE IN THIS AREA



P 7 5 1 5 0 A 0 1 1 2 8

- 12 The points A , B , C and D lie on a circle, centre O .
 $ABCD$ is a rectangle.

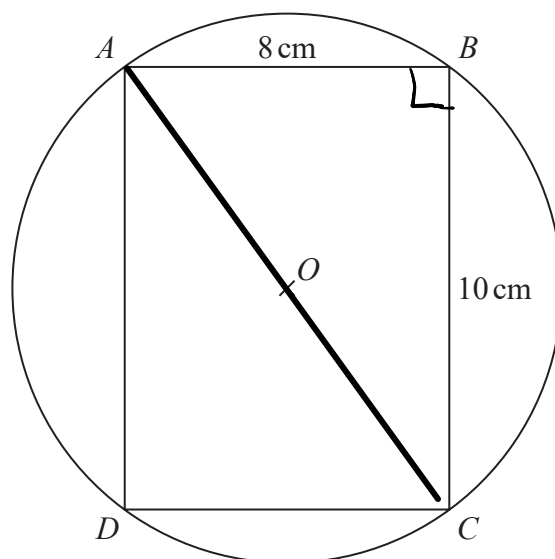

$$AB = 8 \text{ cm} \quad BC = 10 \text{ cm}$$

Work out the circumference of the circle.
 Give your answer correct to 3 significant figures.

$$\begin{aligned} 8^2 + 10^2 &= d^2 \\ 164 &= d^2 \\ d &= \sqrt{164} \\ &= 2\sqrt{41} \end{aligned}$$

$$\begin{aligned} \text{circumference} &= \pi d \\ &= \pi (2\sqrt{41}) \\ &= \underline{\underline{40.2}} \text{ cm} \end{aligned}$$

..... 40.2 cm

(Total for Question 12 is 4 marks)



13 ABC is a triangle.

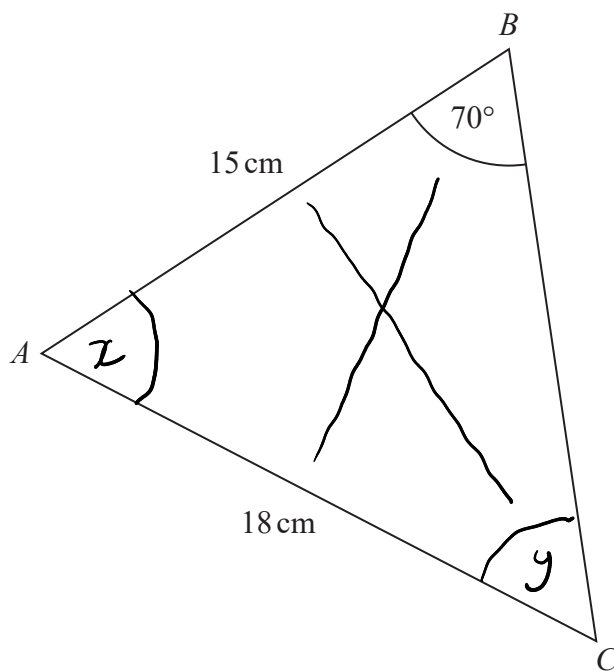

Calculate the size of angle BAC .
Give your answer correct to 1 decimal place.

$$\frac{\sin y}{15} = \frac{\sin 70}{18}$$

$$\sin y = \frac{\sin 70}{18} \times 15$$

$$= 0.783 \dots$$

$$y = 51.5$$

$$x = 180 - 70 - 51.5$$

$$= \underline{\underline{58.5}}$$

.....58.5°

(Total for Question 13 is 4 marks)



- 14 Show that $\frac{x^2 - x - 6}{2x^2 - 5x - 3}$ can be written in the form $\frac{ax + b}{cx + d}$ where a, b, c and d are integers.

$$\frac{(x - 3)(x + 2)}{(2x + 1)(x - 3)}$$

$$\frac{x + 2}{2x + 1}$$

(Total for Question 14 is 3 marks)

- 15 Here are the first four terms of a quadratic sequence.

3 9 17 27

$$\underline{\underline{an^2 + bn + c}}$$

Find an expression, in terms of n , for the n th term of this sequence.

| | | | | | |
|-------------|---------------|---|---|----|----|
| $a + b + c$ | \rightarrow | 3 | 9 | 17 | 27 |
| $3a + b$ | \rightarrow | 6 | 8 | 10 | |
| $2a$ | \rightarrow | 2 | 2 | | |

$$\begin{aligned} 2a &= 2 \\ \underline{a} &= \underline{1} \end{aligned}$$

$$\begin{aligned} 3a + b &= 6 \\ 3 + b &= 6 \\ \underline{b} &= \underline{3} \end{aligned}$$

$$\begin{aligned} a + b + c &= 3 \\ 1 + 3 + c &= 3 \\ \underline{c} &= \underline{-1} \end{aligned}$$

$$n^2 + 3n - 1$$

(Total for Question 15 is 3 marks)



DO NOT WRITE IN THIS AREA

DO NOT WRITE IN THIS AREA

DO NOT WRITE IN THIS AREA

- 16 The histogram gives information about the number of hours some students used their phones last week.
The histogram is incomplete.

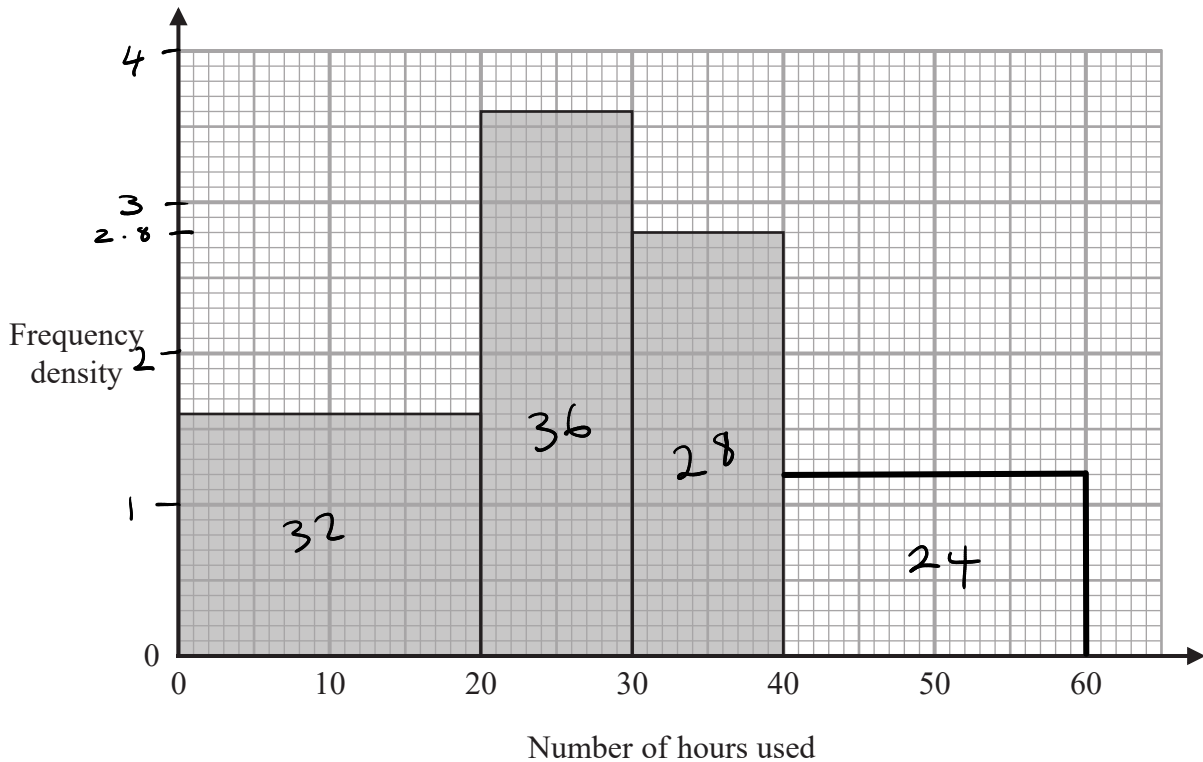

28 students used their phones for between 30 and 40 hours.
24 students used their phones for between 40 and 60 hours.

$$\frac{28}{10} = 2.8$$

- (a) Use this information to complete the histogram.

$$\text{Freq density} = \frac{\text{Freq}}{\text{Classwidth}}$$

$$\frac{24}{20} = \underline{\underline{1.2}}$$

(2)

No student used their phone for more than 60 hours.

- (b) Work out the total number of students.

$$20 \times 1.6 = 32$$

$$10 \times 3.6 = 36$$

$$32 + 36 + 24 + 28 = 120$$

120

(2)

(Total for Question 16 is 4 marks)



P 7 5 1 5 0 A 0 1 5 2 8

17 (a) Show that the equation $x^4 - x^2 - 5 = 0$ can be written in the form $x = \sqrt[4]{x^2 + 5}$

$$x^4 = x^2 + 5$$

$$x = \sqrt[4]{x^2 + 5}$$

(1)

(b) Starting with $x_0 = 1.5$

use the iteration formula $x_{n+1} = \sqrt[4]{x_n^2 + 5}$ three times to find an estimate for a solution of $x^4 - x^2 - 5 = 0$

$$\begin{aligned} x_1 &= \sqrt[4]{(1.5)^2 + 5} \\ &= 1.6409 \dots \end{aligned}$$

$$\begin{aligned} x_2 &= \sqrt[4]{Ans^2 + 5} \\ &= 1.6653 \dots \end{aligned}$$

$$x_3 = 1.6697 \dots$$

$$\underline{1.667763088 \dots}$$

(3)

(Total for Question 17 is 4 marks)



18 $2a:5c = 6:25$
 $4b:7c = 20:21$

Show that $a+b:b+c = 17:20$

$$2a : 5c$$

$$6 : 25$$

$$a : c$$

$$3 : 5$$

$$\times 3$$

$$9 : 15$$

$$4b : 7c$$

$$20 : 21$$

$$b : c$$

$$5 : 3$$

$$\times 5$$

$$25 : 15$$

$$a : b : c$$

$$9 : 25 : 15$$

$$a + b : b + c$$

$$34 : 40$$

$$\underline{\underline{17 : 20}}$$

(Total for Question 18 is 3 marks)



19 ABC is a right-angled triangle.

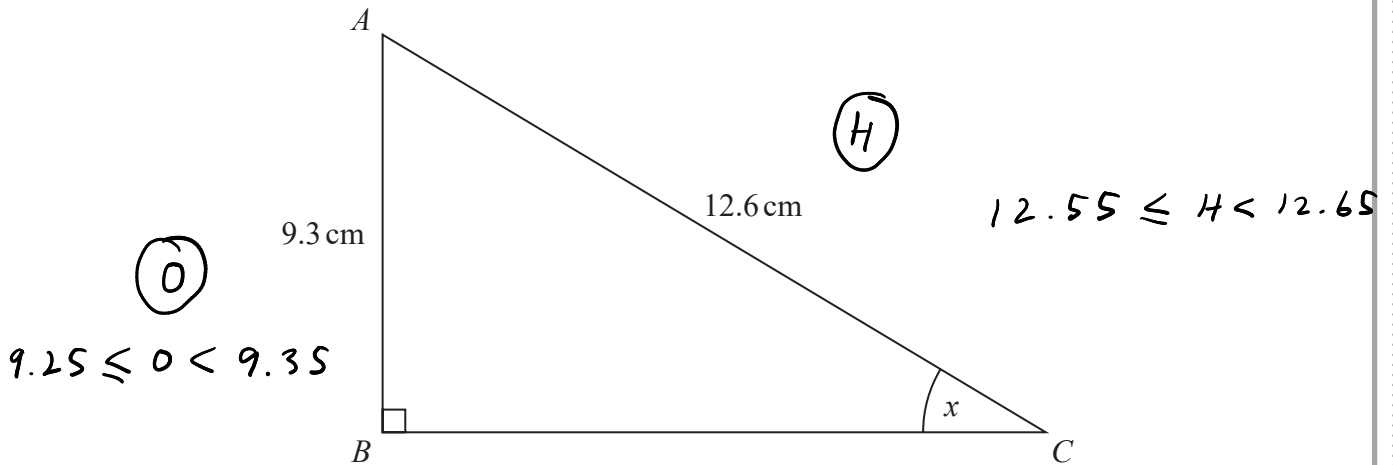

$AB = 9.3$ cm correct to the nearest mm.
 $AC = 12.6$ cm correct to the nearest mm.

Calculate the lower bound for the size of the angle marked x .
 You must show all your working.

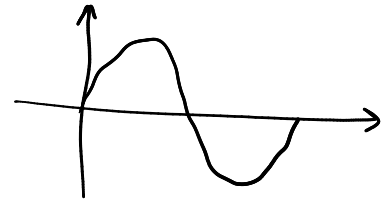

$$\sin x = \frac{O}{H}$$

$$\begin{aligned} \sin x &= \frac{\text{lower } O}{\text{upper } H} \\ &= \frac{9.25}{12.65} \end{aligned}$$

$$\begin{aligned} x &= \sin^{-1}\left(\frac{9.25}{12.65}\right) \\ &= 46.989\dots \end{aligned}$$

47.0 °

(Total for Question 19 is 3 marks)



20 ORT is a triangle.

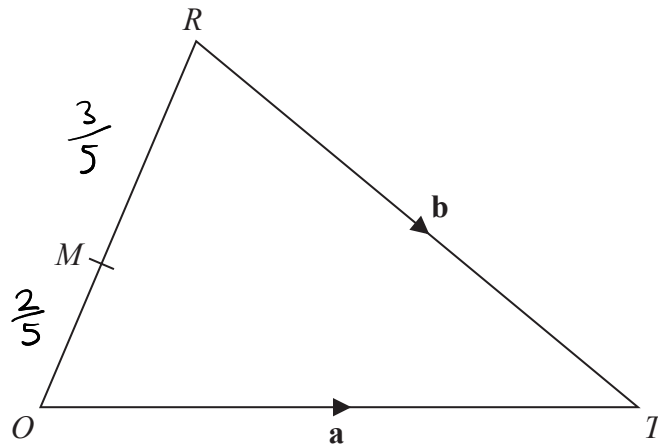

$$\vec{OT} = \mathbf{a} \quad \vec{RT} = \mathbf{b}$$

M is the point on OR such that $OM:MR = 2:3$

Express \vec{MT} in terms of \mathbf{a} and \mathbf{b} .

Give your answer in its simplest form.

$$\vec{OR} = \mathbf{a} - \mathbf{b}$$

$$\vec{MR} = \frac{3}{5}(\mathbf{a} - \mathbf{b})$$

$$\vec{MT} = \vec{MR} + \vec{RT}$$

$$= \frac{3}{5}\mathbf{a} - \frac{3}{5}\mathbf{b} + \mathbf{b}$$

$$= \frac{3}{5}\mathbf{a} + \frac{2}{5}\mathbf{b}$$

$$\underline{\underline{\frac{3}{5}\mathbf{a} + \frac{2}{5}\mathbf{b}}}}$$

(Total for Question 20 is 4 marks)



21 Here is the graph of $y = f(x)$

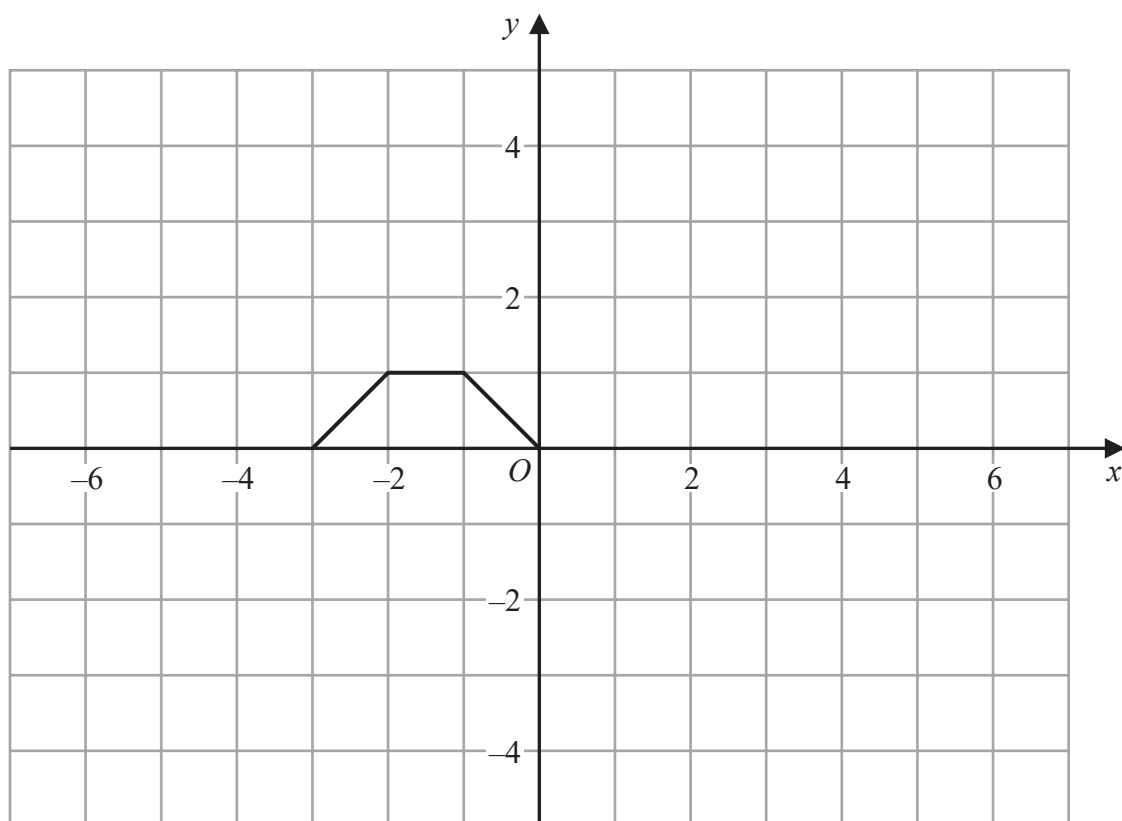

(a) On the grid below, draw the graph of $y = f(x) - 4$

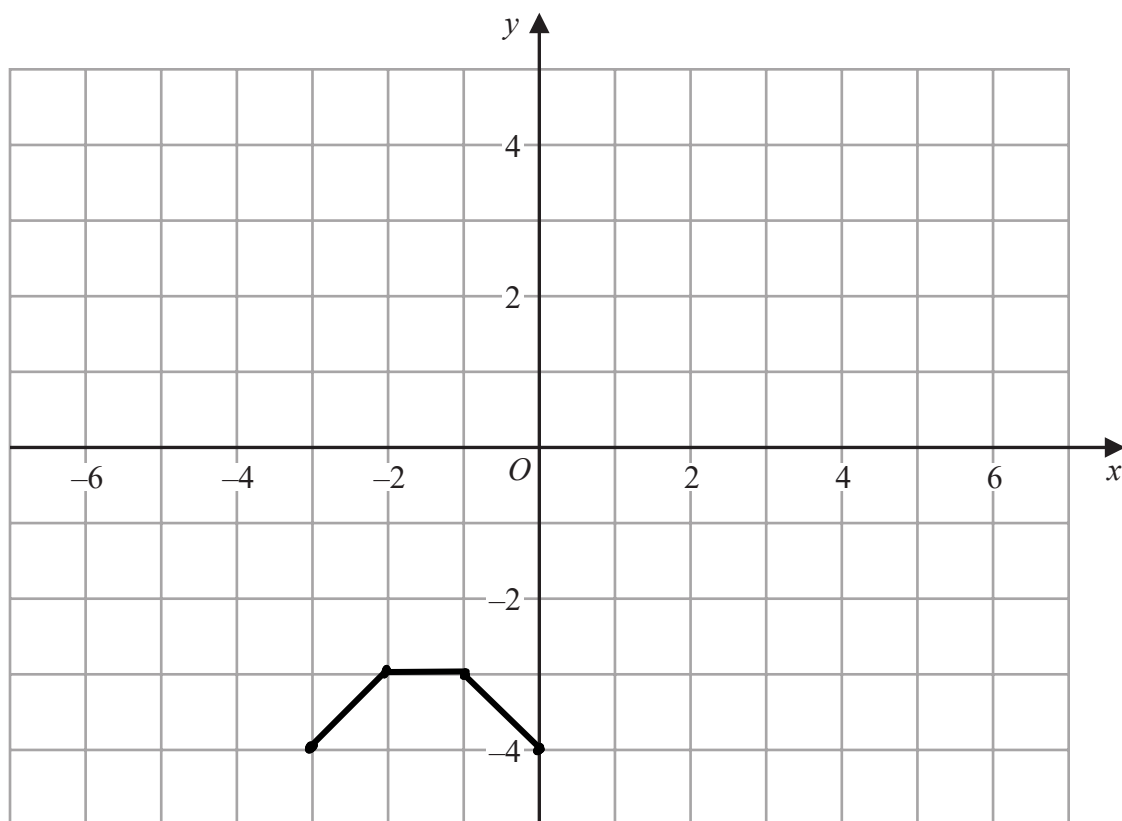

(1)



DO NOT WRITE IN THIS AREA

DO NOT WRITE IN THIS AREA

DO NOT WRITE IN THIS AREA

(b) On the grid below, draw the graph of $y = f(-x)$

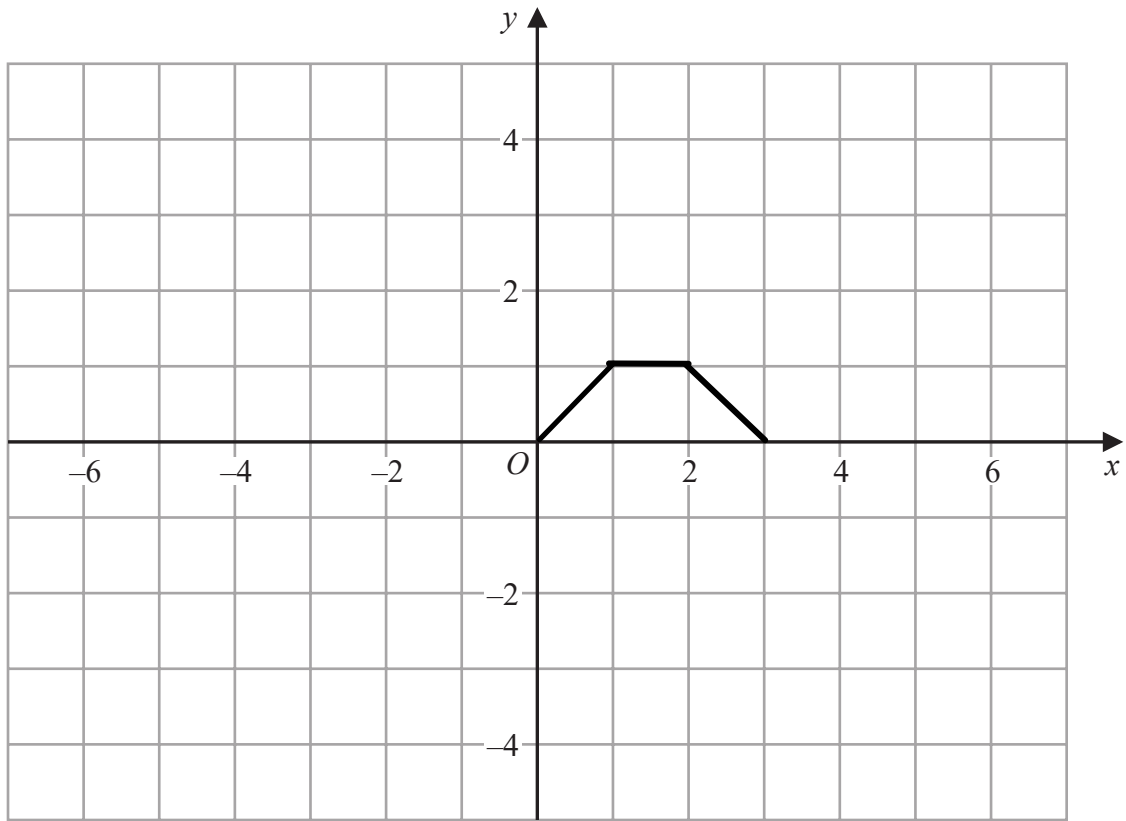

(1)

(Total for Question 21 is 2 marks)



22 There are only blue pens and red pens in a box.

The number of blue pens is four times the number of red pens.

Rita takes at random one pen from the box.

She records the colour of the pen and then replaces it in the box.

Rita does this n times, where $n \geq 2$

Write down an expression, in terms of n , for the probability that Rita gets a blue pen at least once and a red pen at least once.

$$\frac{1}{5} \text{ red} \quad \frac{4}{5} \text{ blue}$$

$$P(\text{All red}) = \left(\frac{1}{5}\right)^n$$

$$P(\text{All blue}) = \left(\frac{4}{5}\right)^n$$

$$P(\text{At least one of each}) = 1 - \left(\frac{1}{5}\right)^n - \left(\frac{4}{5}\right)^n$$

$$1 - \left(\frac{1}{5}\right)^n - \left(\frac{4}{5}\right)^n$$

(Total for Question 22 is 2 marks)



DO NOT WRITE IN THIS AREA

DO NOT WRITE IN THIS AREA

DO NOT WRITE IN THIS AREA

23 Here are three similar triangles, ABG , ACF and ADE .

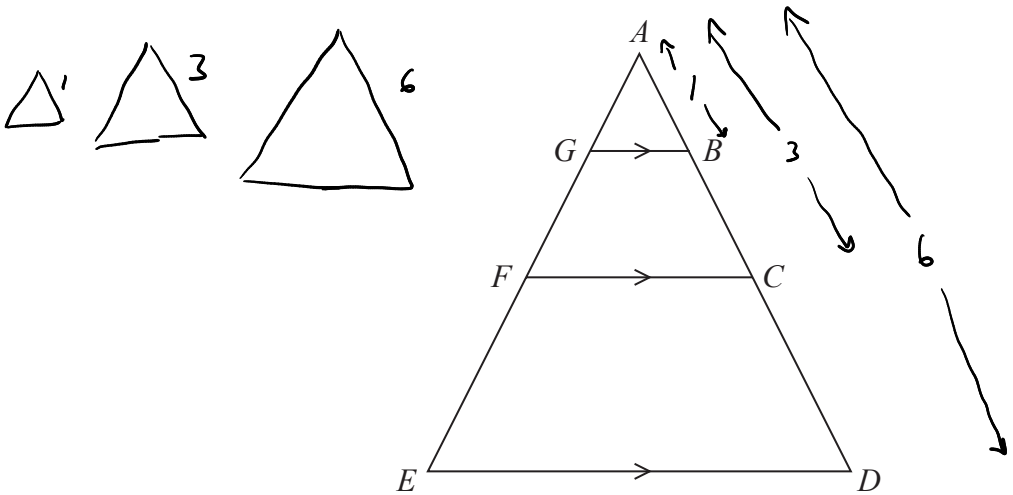

$ABCD$ and $AGFE$ are straight lines.

$$AB:BC:CD = 1:2:3$$

Show that

$$\text{area of } ABG : \text{area of } BCFG : \text{area of } CDEF = 1:8:27$$

scale factor lengths $1:3:6$
 \therefore scale factor areas $1:9:36$

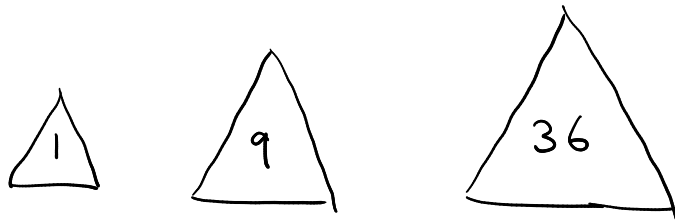

$$\text{Area } ABG = 1$$

$$\text{Area } BCFG = 9 - 1 = 8$$

$$\text{Area } CDEF = 36 - 9 = 27$$

$$\underline{\underline{1 : 8 : 27}}$$

(Total for Question 23 is 3 marks)



P 7 5 1 5 0 A 0 2 3 2 8

24 The diagram shows 8 identical regular octagons joined to enclose a shaded shape.

$$\begin{aligned}
 a^2 + a^2 &= x^2 \\
 2a^2 &= x^2 \\
 \sqrt{2a^2} &= x \\
 a\sqrt{2} &= x
 \end{aligned}$$

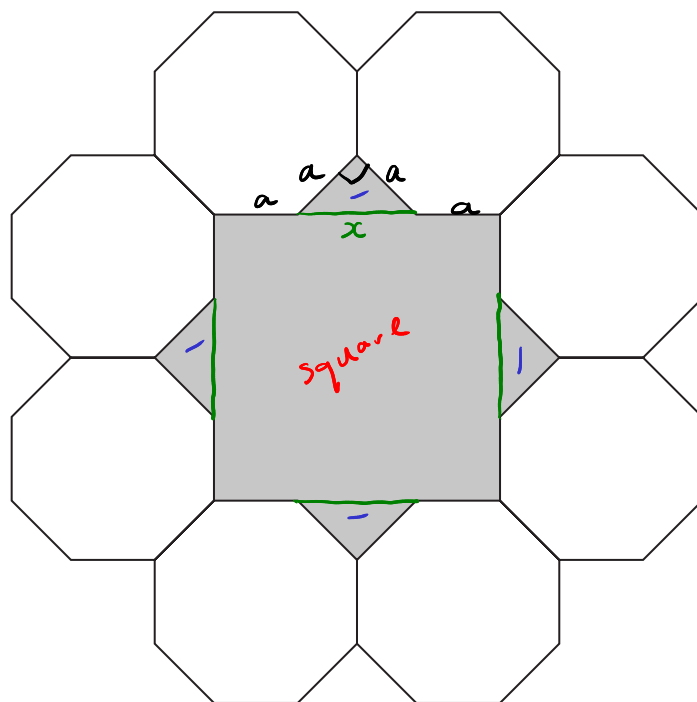

Each octagon has sides of length a .

Find, in terms of a , an expression for the area of the shaded shape.

Give your answer in the form $p(2 + \sqrt{2})a^2$ where p is an integer.

You must show all your working.

$$\begin{aligned}
 \text{Length of square} &= a + a + a\sqrt{2} \\
 &= 2a + a\sqrt{2} \\
 &= (2 + \sqrt{2})a
 \end{aligned}$$

$$\begin{aligned}
 \text{Area of square} &= (2 + \sqrt{2})^2 a^2 \\
 &= \underline{(6 + 4\sqrt{2})a^2}
 \end{aligned}$$

$$\begin{aligned}
 \text{Area of triangle} &= \frac{1}{2} \times a \times a \\
 &= \frac{1}{2} a^2
 \end{aligned}$$

$$4 \times \frac{1}{2} a^2 = \underline{2a^2}$$

$$\begin{aligned}
 \text{Total area} &= (6 + 4\sqrt{2})a^2 + 2a^2 \\
 &= (8 + 4\sqrt{2})a^2 \\
 &= \underline{4(2 + \sqrt{2})a^2}
 \end{aligned}$$



DO NOT WRITE IN THIS AREA

DO NOT WRITE IN THIS AREA

DO NOT WRITE IN THIS AREA

$$4(2 + \sqrt{2})a^2$$

(Total for Question 24 is 5 marks)

TOTAL FOR PAPER IS 80 MARKS



DO NOT WRITE IN THIS AREA

DO NOT WRITE IN THIS AREA

DO NOT WRITE IN THIS AREA

BLANK PAGE



DO NOT WRITE IN THIS AREA

DO NOT WRITE IN THIS AREA

DO NOT WRITE IN THIS AREA

BLANK PAGE



P 7 5 1 5 0 A 0 2 7 2 8

DO NOT WRITE IN THIS AREA

DO NOT WRITE IN THIS AREA

DO NOT WRITE IN THIS AREA

BLANK PAGE

