

Write your name here

Surname

Other names

Pearson
Edexcel GCSE

Centre Number

--	--	--	--	--	--

Candidate Number

--	--	--	--	--

2015 Predicted Paper 2

Higher Tier

Time: 1 hour 45 minutes

Paper Reference

1MA0/2H

You must have: Ruler graduated in centimetres and millimetres, protractor, pair of compasses, pen, HB pencil, eraser, calculator. Tracing paper may be used.

Total Marks



Instructions

- Use **black** ink or ball-point pen.
- **Fill in the boxes** at the top of this page with your name, centre number and candidate number.
- Answer **all** questions.
- Answer the questions in the spaces provided – *there may be more space than you need.*
- **Calculators may be used.**
- If your calculator does not have a π button, take the value of π to be 3.142 unless the question instructs otherwise.

Information

- The total mark for this paper is 100
- The marks for **each** question are shown in brackets – *use this as a guide as to how much time to spend on each question.*
- Questions labelled with an **asterisk** (*) are ones where the quality of your written communication will be assessed.

Advice

- Read each question carefully before you start to answer it.
- Keep an eye on the time.
- Try to answer every question.
- Check your answers if you have time at the end.

GCSE Mathematics 1MA0

Formulae: Higher Tier

**You must not write on this formulae page.
Anything you write on this formulae page will gain NO credit.**

Volume of prism = area of cross section \times length

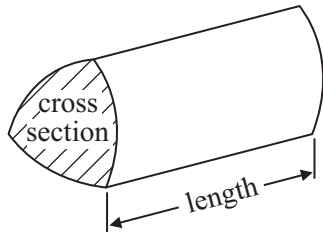

Area of trapezium = $\frac{1}{2} (a + b)h$

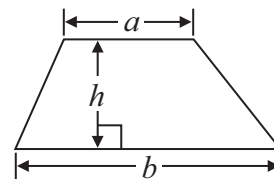

Volume of sphere = $\frac{4}{3} \pi r^3$

Surface area of sphere = $4\pi r^2$

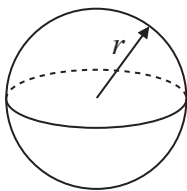

Volume of cone = $\frac{1}{3} \pi r^2 h$

Curved surface area of cone = $\pi r l$

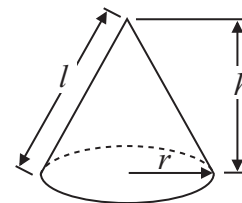

In any triangle ABC

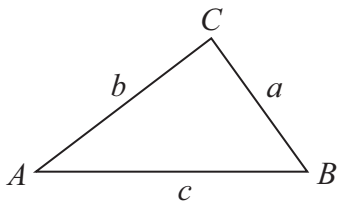

The Quadratic Equation

The solutions of $ax^2 + bx + c = 0$
where $a \neq 0$, are given by

$$x = \frac{-b \pm \sqrt{b^2 - 4ac}}{2a}$$

Sine Rule $\frac{a}{\sin A} = \frac{b}{\sin B} = \frac{c}{\sin C}$

Cosine Rule $a^2 = b^2 + c^2 - 2bc \cos A$

Area of triangle = $\frac{1}{2} ab \sin C$

Answer ALL questions.

Write your answers in the spaces provided.

You must write down all stages in your working.

1 (a) Work out the reciprocal of 1.25

.....
(1)

(b) Work out the value of $\frac{9.6}{\sqrt{5} - 1.7}$

Give your answer correct to 2 decimal places.

.....
(2)

(Total for Question 1 is 3 marks)

2 Becky counted the number of matches in each of 50 boxes.
The table shows information about her results.

Number of matches	Frequency
45	3
46	7
47	12
48	23
49	4
50	1

Work out the mean number of matches.

.....
(Total for Question 2 is 3 marks)

3

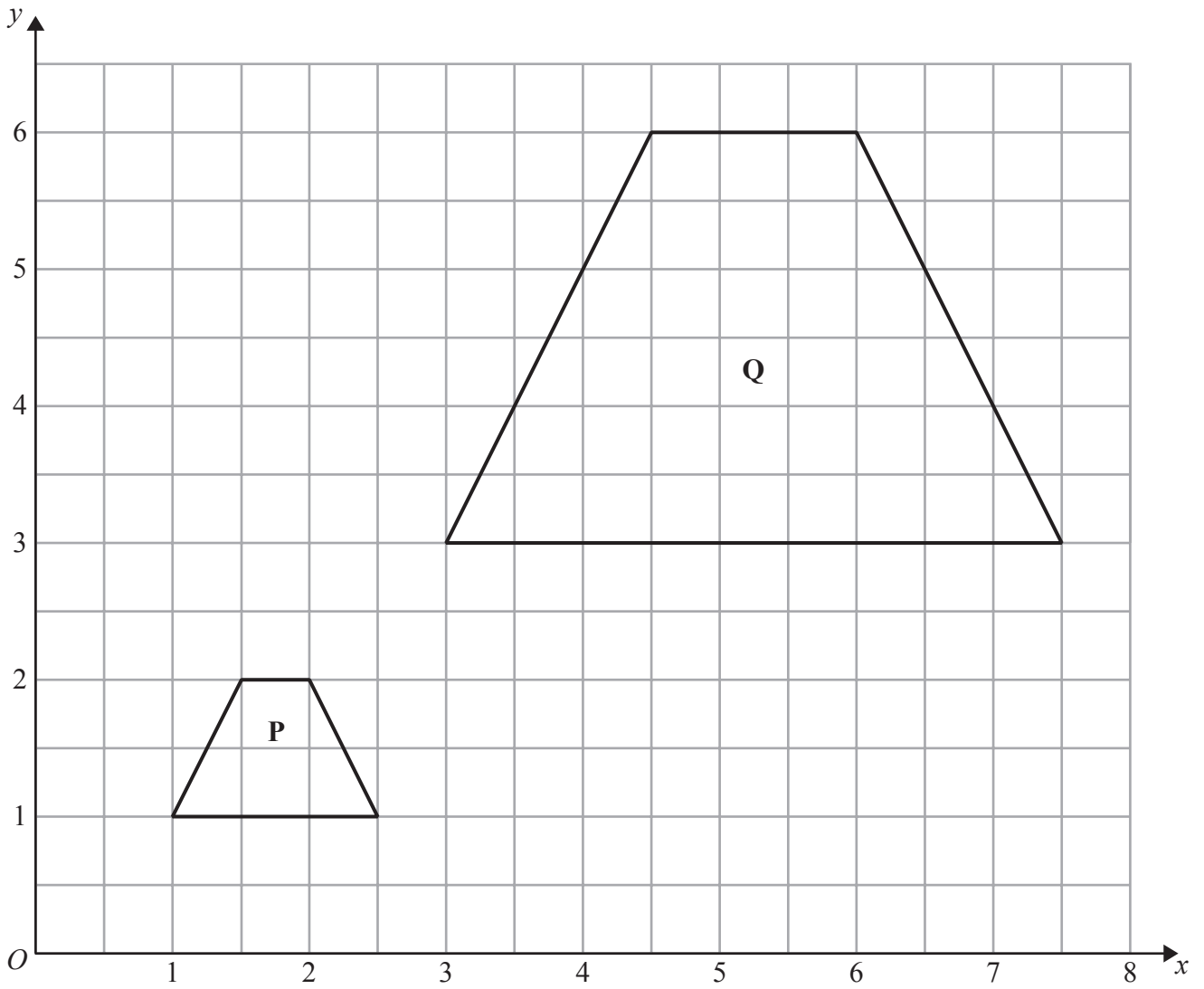

Describe fully the single transformation that maps shape **P** onto shape **Q**.

.....

.....

(Total for Question 3 is 3 marks)

*4 Tea bags are sold in three sizes of box.

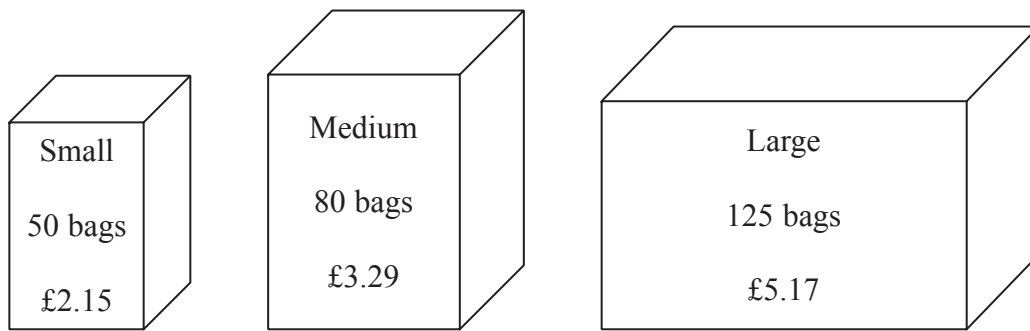

A small box of 50 tea bags costs £2.15

A medium box of 80 tea bags costs £3.29

A large box of 125 tea bags costs £5.17

Which size of box is the best value for money?

(Total for Question 4 is 4 marks)

5 Jalin lives in England.
He does a search on the internet and sees the same type of camera on sale in France and in America.

In France, the camera costs 126 euros.

In America, the camera costs \$165.24

Jalin finds out these exchange rates.

Exchange rates

1 euro = £0.89

£1 = \$1.62

How much cheaper is the camera in America than in France?
Give your answer in pounds (£).

£

(Total for Question 5 is 4 marks)

6 The diagram shows the positions of two shops, A and B , on a map.

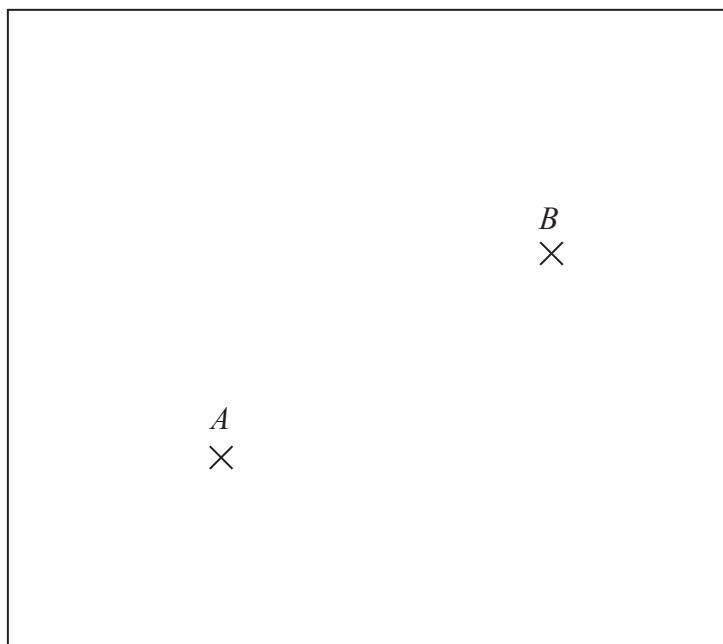

The scale of the map is 1 cm represents 5 km.

Yannis wants to build a warehouse.

The warehouse needs to be

less than 10 km from A ,
less than 20 km from B .

Show by shading where Yannis can build the warehouse.

(Total for Question 6 is 3 marks)

7 The equation $x^3 + 27x = 90$

has a solution between 2 and 3

Use a trial and improvement method to find this solution.

Give your answer correct to one decimal place.

You must show all your working.

$x = \dots\dots\dots$

(Total for Question 7 is 4 marks)

8 On an activity day students play one sport.

They play football or hockey or tennis.

120 students are on the activity day.

30 of the students are boys.

12 of the boys and 26 of the girls play hockey.

45 of the students play football.

35 of the 45 students who play football are girls.

Work out the number of girls who play tennis.

(Total for Question 8 is 4 marks)

9

Diagram **NOT**
accurately drawn

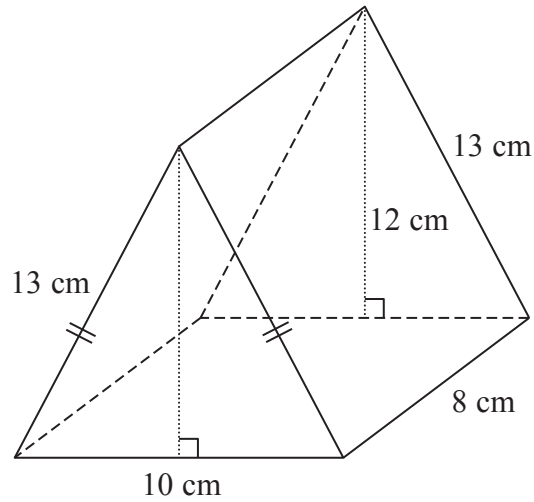

The diagram shows a prism.
The cross-section of the prism is an isosceles triangle.
The lengths of the sides of the triangle are 13 cm, 13 cm and 10 cm.
The perpendicular height of the triangle is 12 cm.
The length of the prism is 8 cm.

Work out the total surface area of the prism.

..... cm²

(Total for Question 9 is 3 marks)

10 The diagram shows a trundle wheel.

Diagram **NOT**
accurately drawn

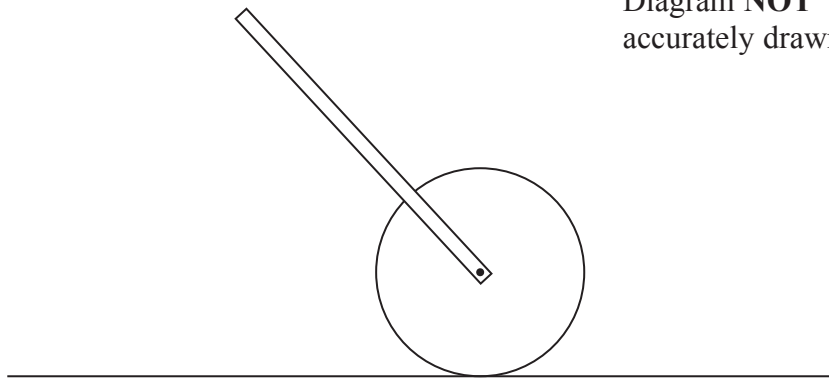

Trundle wheels are used to measure distances along the ground.

The radius of the trundle wheel is 20 cm.

Jim wants to work out the distance between two junctions on a road.
He rolls the trundle wheel between the two junctions.

The trundle wheel rotates exactly 34 times.

Work out the distance between the two junctions.
Give your answer in metres correct to the nearest metre.

.....m

(Total for Question 10 is 3 marks)

11 (a) Complete the table of values for $y = x^2 + 2x - 3$

x	-4	-3	-2	-1	0	1	2
y		0	-3	-4			5

(2)

(b) On the grid, draw the graph of $y = x^2 + 2x - 3$ for values of x from -4 to 2

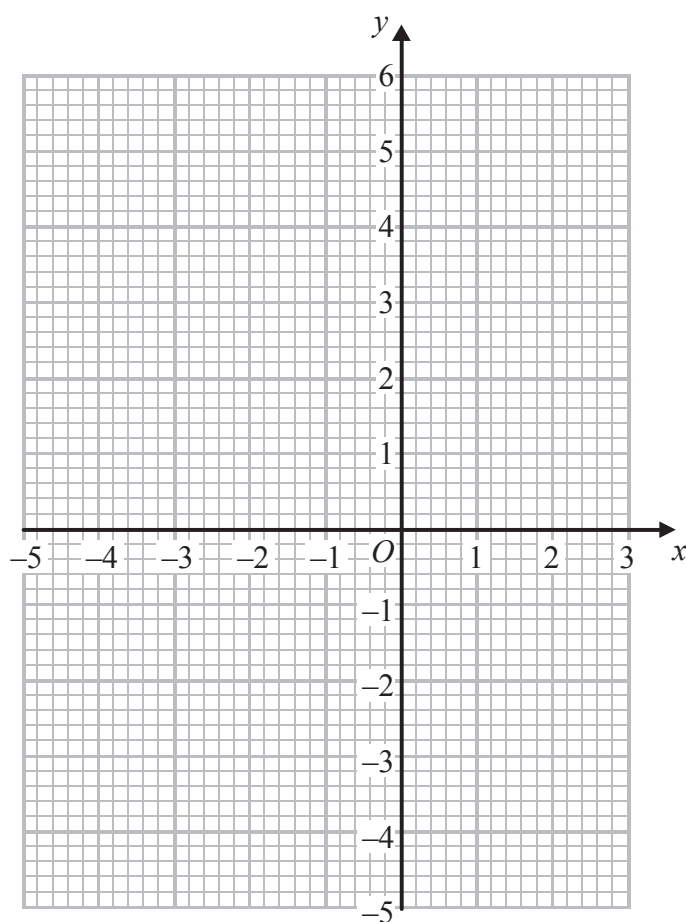

(2)

(Total for Question 11 is 4 marks)

12 (a) Helen's savings increased from £155 to £167.40

Work out the percentage increase in Helen's savings.

..... %

(3)

(b) Joe's savings increased by 4.5%.

His savings are now £125.40

What were his savings before the increase?

£.....

(3)

(Total for Question 12 is 6 marks)

13 (a) Write 0.000076 in standard form.

.....
(1)

The area covered by the Pacific Ocean is $1.6 \times 10^8 \text{ km}^2$

The area covered by the Arctic Ocean is $1.4 \times 10^7 \text{ km}^2$

(b) Write 1.6×10^8 as an ordinary number.

.....
(1)

The area covered by the Pacific Ocean is k times the area covered by the Arctic Ocean.

(c) Find, correct to the nearest integer, the value of k .

$k =$
(2)

(Total for Question 13 is 4 marks)

14 Kwo invests HK\$ 40000 for 3 years at 2.5% per year compound interest.

Work out the value of the investment at the end of 3 years.

HK\$

(Total for Question 14 is 3 marks)

15 (a) Simplify $8d \times 7d$

.....
(1)

(b) Expand $4(3e - 5)$

.....
(1)

(c) Expand and simplify $(2x + 1)(x + 3)$

.....
(2)

(Total for Question 15 is 4 marks)

16

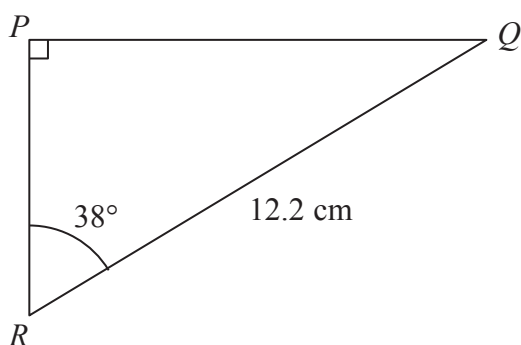

Diagram NOT
accurately drawn

Calculate the length of PQ .
Give your answer correct to 3 significant figures.

..... cm

(Total for Question 16 is 3 marks)

*17 Paper clips are sold in small boxes and in large boxes.

There is a total of 1115 paper clips in 4 small boxes and 5 large boxes.

There is a total of 530 paper clips in 3 small boxes and 2 large boxes.

Work out the number of paper clips in each small box and in each large box.

(Total for Question 17 is 5 marks)

18 Presta recorded the number of lemons on each of 60 lemon trees.

The incomplete table and box plot give information about her results.

	Number of lemons
Smallest number	
Lower quartile	8
Median	11
Upper quartile	
Greatest number	22

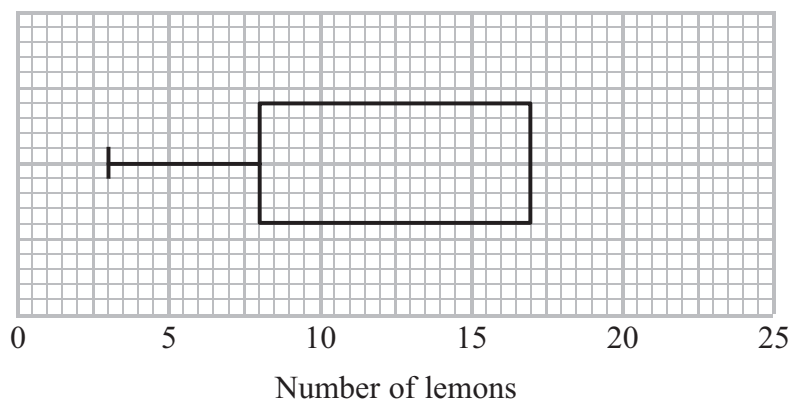

(a) (i) Use the information in the table to complete the box plot.

(ii) Use the information in the box plot to complete the table.

(3)

Some of these 60 lemon trees have 8 or more lemons on them.

(b) Find an estimate for the number of lemon trees with 8 or more lemons on them.

(2)

(Total for Question 18 is 5 marks)

19

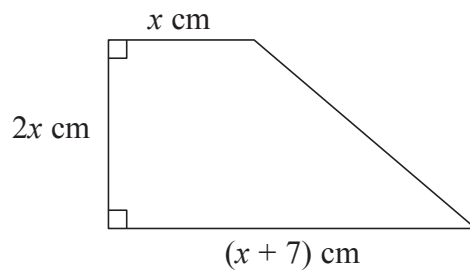

Diagram **NOT**
accurately drawn

The diagram shows a trapezium.
The trapezium has an area of 17 cm^2

(a) Show that $2x^2 + 7x - 17 = 0$

(3)

(b) Work out the value of x .
Give your answer correct to 3 significant figures.
Show your working clearly.

$x = \dots\dots\dots$
(3)

(Total for Question 19 is 6 marks)

Diagram **NOT**
accurately drawn

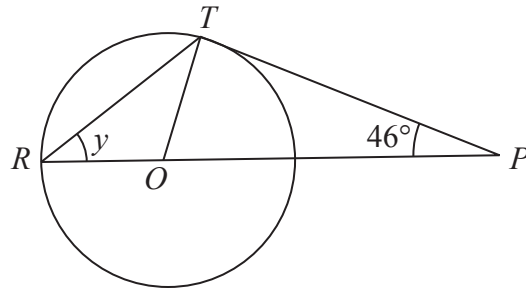

R and T are points on a circle, centre O .

ROP is a straight line.

PT is a tangent to the circle.

Angle $TPO = 46^\circ$

(a) Explain why angle $OTP = 90^\circ$

(1)

(b) Work out the size of angle y .

(3)

(Total for Question 20 is 4 marks)

21 F is inversely proportional to the square of x .
 $F = 0.8$ when $x = 5$

(a) Find a formula for F in terms of x .

.....
(3)

(b) Work out the positive value of x when $F = 320$

$x =$
(2)

(Total for Question 21 is 5 marks)

22 156 students went to London.

Each student visited one of the British Museum or the National Gallery or the Stock Exchange.

The table gives information about these students.

	Place visited		
	British Museum	National Gallery	Stock Exchange
Male	25	18	35
Female	27	32	19

Kate takes a sample of 30 of these students.

The sample is stratified by place visited and by gender.

Work out the number of male students who visited the Stock Exchange in the sample.

.....
(Total for Question 22 is 2 marks)

23

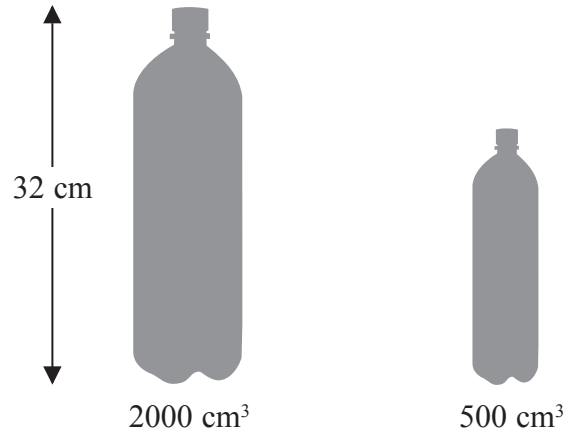

Diagram **NOT**
accurately drawn

Zane buys mineral water in large bottles and in small bottles.
The large bottles are mathematically similar to the small bottles.
Large bottles have a height of 32 cm and a volume of 2000 cm³
Small bottles have a volume of 500 cm³

Work out the height of a small bottle.
Give your answer correct to 3 significant figures.

..... cm

(Total for Question 23 is 3 marks)

24 The table shows some information about the total rainfall, in millimetres, recorded at 85 weather stations one month.

Rainfall (mm)	Frequency
$0 < x \leq 20$	16
$20 < x \leq 30$	27
$30 < x \leq 45$	36
$45 < x \leq 50$	6

(a) Draw a histogram for this information.

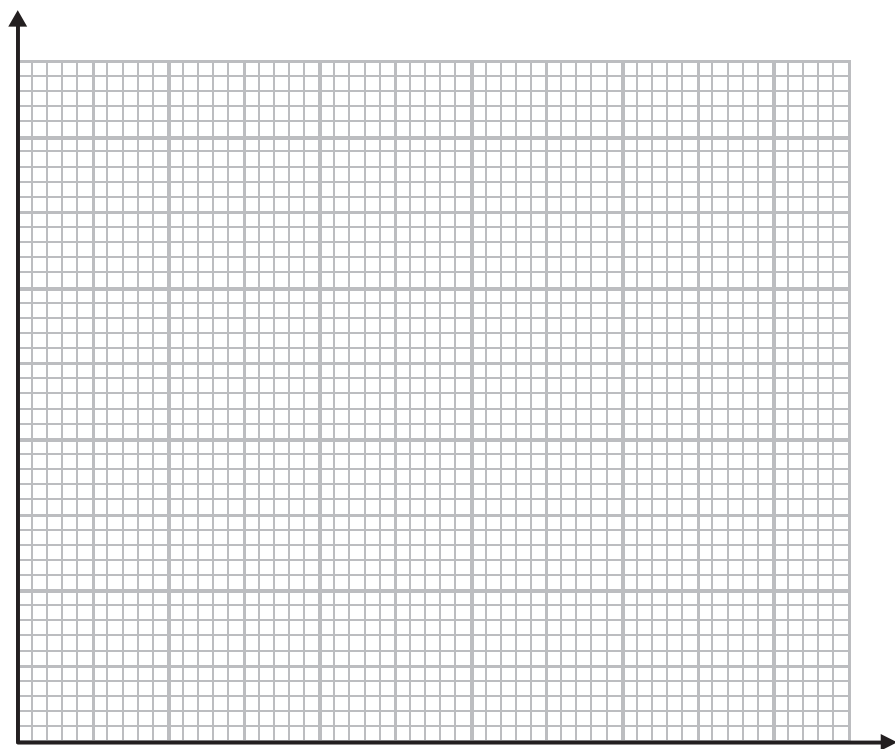

(3)

(b) One of the weather stations is selected at random.
Work out the probability that the rainfall recorded was over 40 mm.

.....
(3)

(Total for Question 24 is 6 marks)

25 Jerry wants to cover a triangular field, ABC , with fertiliser.

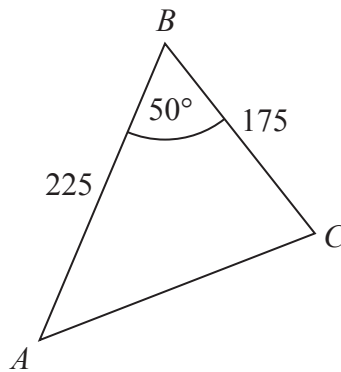

Diagram **NOT**
accurately drawn

Here are the measurements Jerry makes

angle $ABC = 50^\circ$ correct to the nearest degree,
 $BA = 225$ m correct to the nearest 5 m,
 $BC = 175$ m correct to the nearest 5 m.

Work out the upper bound for the area of the field.
You must show your working.

..... m²

(Total for Question 25 is 3 marks)

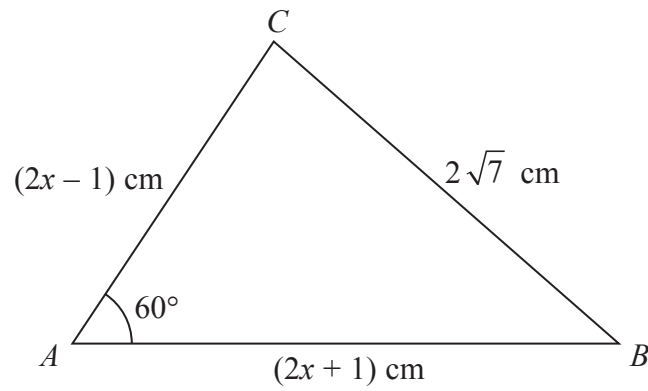

Diagram **NOT**
accurately drawn

The diagram shows a triangle ABC .

$AB = (2x + 1)$ cm, $AC = (2x - 1)$ cm and $BC = 2\sqrt{7}$ cm.

Angle $BAC = 60^\circ$

Work out the value of x .

Show clear algebraic working.

$x = \dots\dots\dots$

(Total for Question 26 is 3 marks)

TOTAL FOR PAPER IS 100 MARKS