

Name: _____

GCSE (1 – 9)

The Cosine Rule

Instructions

- Use **black** ink or ball-point pen.
- Answer all questions.
- Answer the questions in the spaces provided
– *there may be more space than you need.*
- Diagrams are **NOT** accurately drawn, unless otherwise indicated.
- You must **show all your working out.**

Information

- The marks for each question are shown in brackets
– *use this as a guide as to how much time to spend on each question.*

Advice

- Read each question carefully before you start to answer it.
- Keep an eye on the time.
- Try to answer every question.
- Check your answers if you have time at the end

1

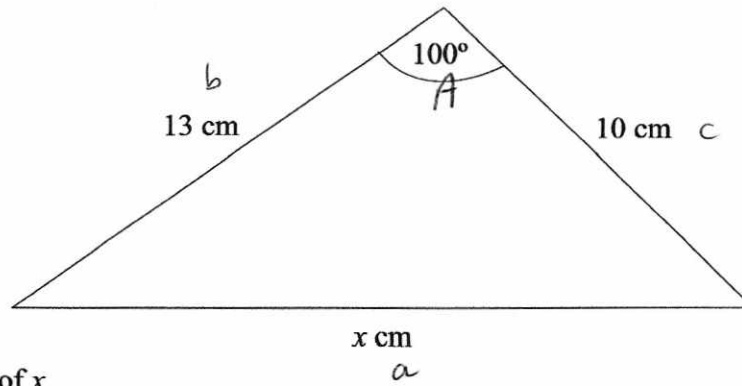

Work out the value of x .

Give your answer to 1 decimal place.

$$a^2 = b^2 + c^2 - 2bc \cos A$$

$$x^2 = (13)^2 + (10)^2 - 2(13)(10) \cos(100)$$

$$x^2 = 314.1485\dots$$

$$x = \sqrt{\text{Ans}}$$

$$= \underline{\underline{17.7}} \text{ (1dp)}$$

.....17.7

(Total for question 1 is 3 marks)

2

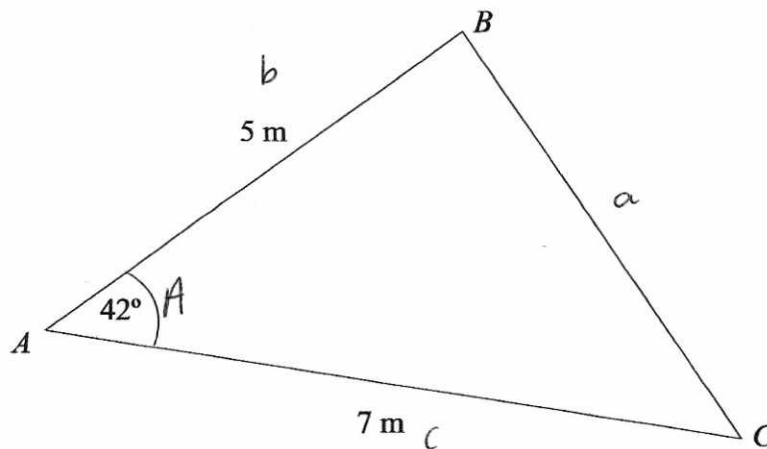

Work out the length of BC.

Give your answer to 3 significant figures.

$$a^2 = (5)^2 + (7)^2 - 2(5)(7) \cos(42)$$

$$a^2 = 21.97986\dots$$

$$a = \sqrt{\text{Ans}}$$

$$= 4.69 \text{ (3sf)}$$

.....4.69

(Total for question 2 is 3 marks)

3

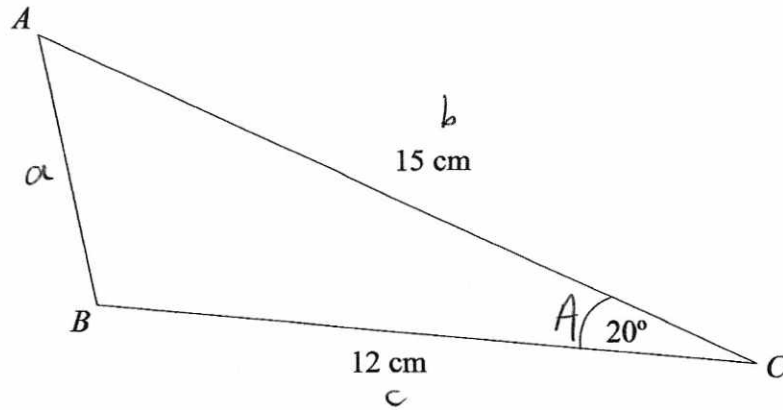

Work out the length of AB.

Give your answer to 1 decimal place.

$$a^2 = (15)^2 + (12)^2 - 2(15)(12)\cos(20)$$

$$a^2 = 30.7106\dots$$

$$a = \sqrt{\text{Ans}}$$

$$a = 5.5 \text{ (1dp)}$$

.....5.5.....cm

(Total for question 3 is 3 marks)

4

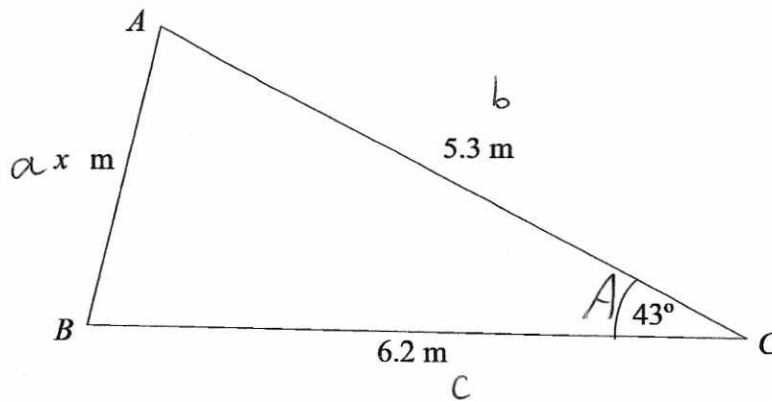

Work out the value of x.

Give your answer to 3 significant figures.

$$x^2 = (5.3)^2 + (6.2)^2 - 2(5.3)(6.2)\cos(43)$$

$$x^2 = 18.4654\dots$$

$$x = \sqrt{\text{Ans}}$$

$$x = 4.30 \text{ (3sf)}$$

.....4.30.....

(Total for question 4 is 3 marks)

5

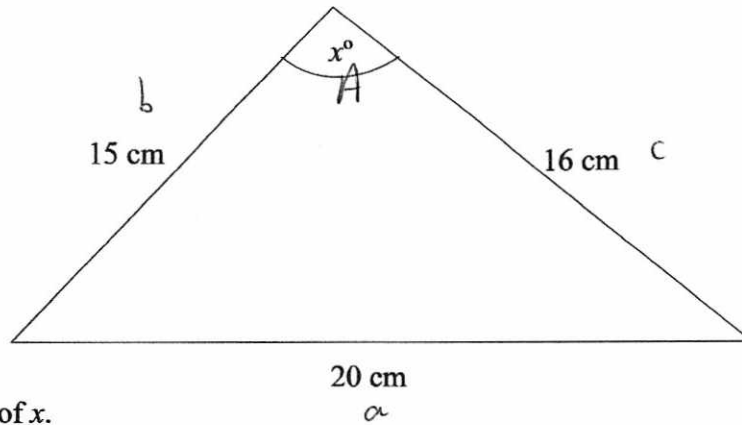

Work out the value of x .

Give your answer to 3 significant figures.

$$\cos A = \frac{b^2 + c^2 - a^2}{2bc}$$

$$\cos x = \frac{(15)^2 + (16)^2 - (20)^2}{2(15)(16)}$$

$$\cos x = \frac{27}{160}$$

$$x = \cos^{-1}(\text{Ans})$$

$$= 80.3 \text{ (3sf)}$$

.....80.3

(Total for question 5 is 3 marks)

6

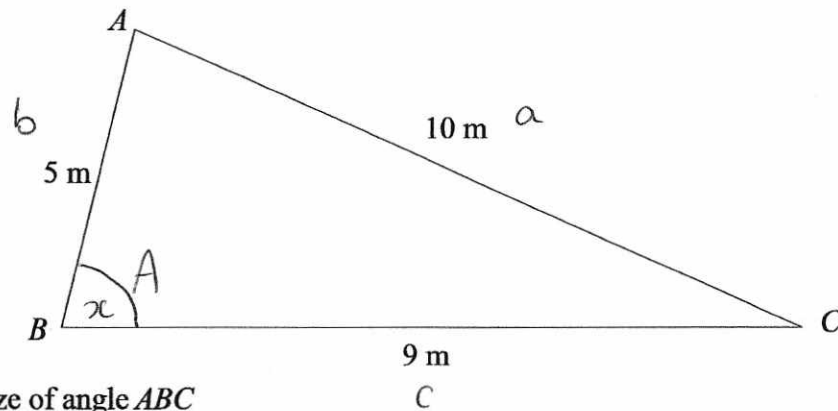

Work out the size of angle ABC

Give your answer to the nearest degree.

$$\cos x = \frac{(5)^2 + (9)^2 - (10)^2}{2(5)(9)}$$

$$\cos x = \frac{1}{15}$$

$$x = \cos^{-1}(\text{Ans})$$

$$= 86 \text{ (nearest degree)}$$

.....86

(Total for question 6 is 3 marks)

7

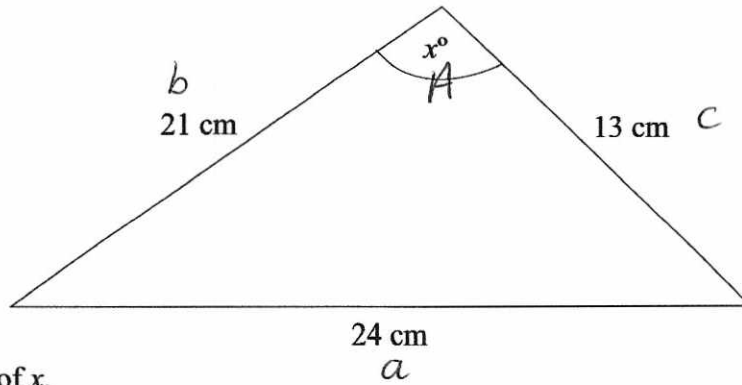

Work out the value of x .
Give your answer to 1 decimal place.

$$\cos x = \frac{(21)^2 + (13)^2 - (24)^2}{2(21)(13)}$$

$$\cos x = \frac{17}{273}$$

$$x = \cos^{-1}(\text{Ans})$$

$$= 86.4 \text{ (1dp)}$$

86.4

(Total for question 7 is 3 marks)

8

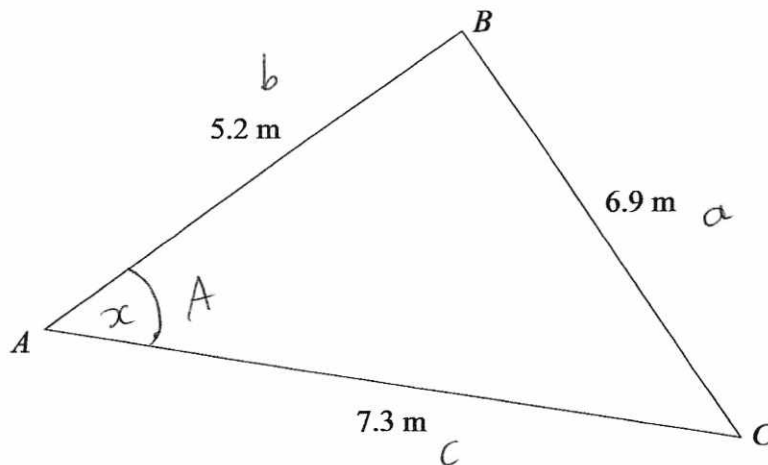

Work out the size of angle BAC.
Give your answer to 3 significant figures.

$$\cos x = \frac{(5.2)^2 + (7.3)^2 - (6.9)^2}{2(5.2)(7.3)}$$

$$\cos x = \frac{409}{949}$$

$$x = \cos^{-1}(\text{Ans})$$

$$= 64.5 \text{ (3sf)}$$

64.5

(Total for question 8 is 3 marks)

9

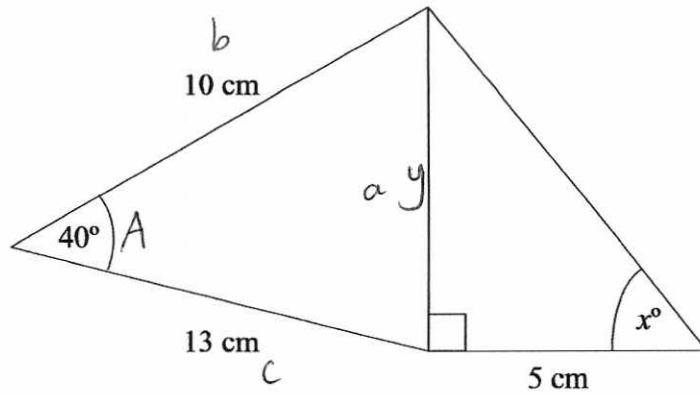

Work out the value of x .
Give your answer to 1 decimal place.

$$y^2 = (10)^2 + (13)^2 - 2(10)(13) \cos(40)$$

$$y^2 = 69.828\dots$$

$$y = \sqrt{\text{Ans}}$$

$$y = 8.356341591$$

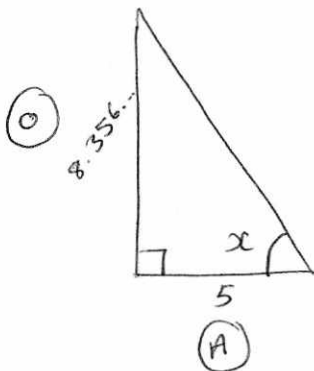

$$\tan x = \frac{\text{Ans}}{5}$$

$$x = \tan^{-1}\left(\frac{\text{Ans}}{5}\right)$$

$$= 59.1^\circ \quad (1\text{dp})$$

59.1

(Total for question 9 is 5 marks)

10

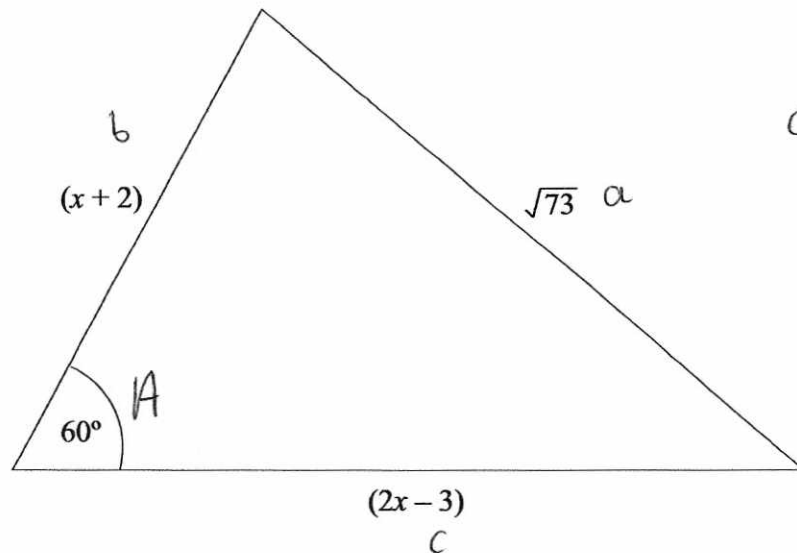

$$\cos 60 = \frac{1}{2}$$

Work out the value of x .

$$a^2 = b^2 + c^2 - 2bc \cos A$$

$$73 = (x+2)^2 + (2x-3)^2 - 2(x+2)(2x-3) \cos(60)$$

$$73 = (x+2)(x+2) + (2x-3)(2x-3) - (x+2)(2x-3)$$

$$73 = x^2 + 2x + 2x + 4 + 4x^2 - 6x - 6x + 9 - (2x^2 - 3x + 4x - 6)$$

$$73 = 5x^2 - 8x + 13 - (2x^2 + x - 6)$$

$$73 = 3x^2 - 9x + 19$$

$$0 = 3x^2 - 9x - 54$$

$$0 = x^2 - 3x - 18$$

$$0 = (x - 6)(x + 3)$$

$$x = 6 \quad x = -3$$

x cannot be -3 as the lengths would be negative.

$$\underline{\underline{x = 6}}$$

6

(Total for question 10 is 5 marks)

11

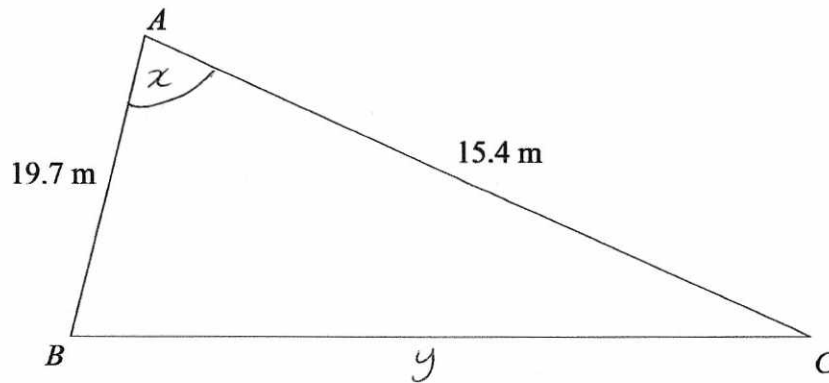

The area of the triangle is 100m^2
 Calculate the perimeter of triangle ABC .
 Give your answer to 3 significant figures.

$$\frac{1}{2} a b \sin C = 100$$

$$\frac{1}{2} (19.7)(15.4) \sin x = 100$$

$$151.69 \sin x = 100$$

$$\sin x = \frac{100}{151.69}$$

$$x = \sin^{-1}\left(\frac{100}{151.69}\right)$$

$$= 41.24187853$$

$$y^2 = (19.7)^2 + (15.4)^2 - 2(19.7)(15.4) \cos(41.24187\dots)$$

$$y^2 = 169.0069753$$

$$y = \sqrt{\text{Ans}}$$

$$= 13.0 \text{ (3sf)}$$

$$\text{Perimeter} = 19.7 + 15.4 + 13.0$$

$$= 48.1 \text{ m}$$

.....48.1.....m

(Total for question 11 is 5 marks)