

Write your name here

Surname

Other Names

# Mathematics

## June 2023 Practice Paper 3 (Calculator) Foundation Tier

Time: 1 hour 30 minutes

**You must have:** Ruler graduated in centimetres and millimetres, protractor, pair of compasses, pen, HB pencil, eraser, calculator. Tracing paper may be used.

Total Marks

### Instructions

- Use **black** ink or ball-point pen.
- **Fill in the boxes** at the top of this page with your name, centre number and candidate number.
- Answer **all** questions.
- Answer the questions in the spaces provided  
– there may be more space than you need.
- **Calculators may be used.**
- Diagrams are **NOT** accurately drawn, unless otherwise indicated.
- You must **show all your working.**

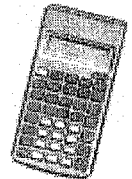

### Information

- The total mark for this paper is 80
- The marks for **each** question are shown in brackets  
– use this as a guide as to how much time to spend on each question.

### Advice

- Read each question carefully before you start to answer it.
- Keep an eye on the time.
- Try to answer every question.
- Check your answers if you have time at the end.

## Foundation Tier Formulae Sheet

### Perimeter, area and volume

Where  $a$  and  $b$  are the lengths of the parallel sides and  $h$  is their perpendicular separation:

$$\text{Area of a trapezium} = \frac{1}{2}(a + b)h$$

Volume of a prism = area of cross section  $\times$  length

Where  $r$  is the radius and  $d$  is the diameter:

$$\text{Circumference of a circle} = 2\pi r = \pi d$$

$$\text{Area of a circle} = \pi r^2$$

### Pythagoras' Theorem and Trigonometry

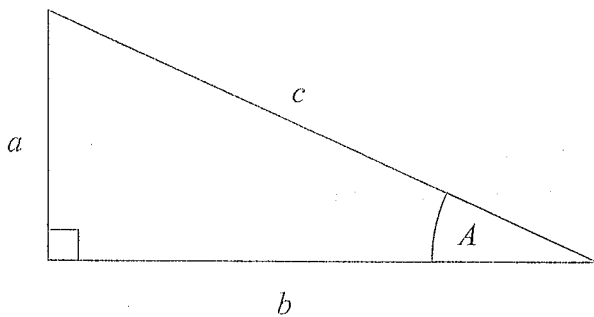

In any right-angled triangle where  $a$ ,  $b$  and  $c$  are the length of the sides and  $c$  is the hypotenuse:

$$a^2 + b^2 = c^2$$

In any right-angled triangle  $ABC$  where  $a$ ,  $b$  and  $c$  are the length of the sides and  $c$  is the hypotenuse:

$$\sin A = \frac{a}{c} \quad \cos A = \frac{b}{c} \quad \tan A = \frac{a}{b}$$

### Compound Interest

Where  $P$  is the principal amount,  $r$  is the interest rate over a given period and  $n$  is number of times that the interest is compounded:

$$\text{Total accrued} = P \left( 1 + \frac{r}{100} \right)^n$$

### Probability

Where  $P(A)$  is the probability of outcome  $A$  and  $P(B)$  is the probability of outcome  $B$ :

$$P(A \text{ or } B) = P(A) + P(B) - P(A \text{ and } B)$$

**END OF EXAM AID**

1 Write down two factors of 20

$$1 \times 20$$

$$2 \times 10$$

$$4 \times 5$$

Any 2 of 1, 2, 4, 5, 10 and 20

4 and 5

(Total for Question 1 is 1 mark)

2 Write 40% as a fraction.

$$\frac{40}{100}$$

or any simplified eg  $\frac{2}{5}$

$$\frac{40}{100}$$

(Total for Question 2 is 1 mark)

3 Write down a 6 digit number that has 7 as its hundreds digit.  
You can only use the digit 7 once.

100700

(Total for Question 3 is 1 mark)

4 Write 78.54 correct to one significant figure

80

(Total for Question 4 is 1 mark)

5 The graph shows some information about car production in the UK over eight years.

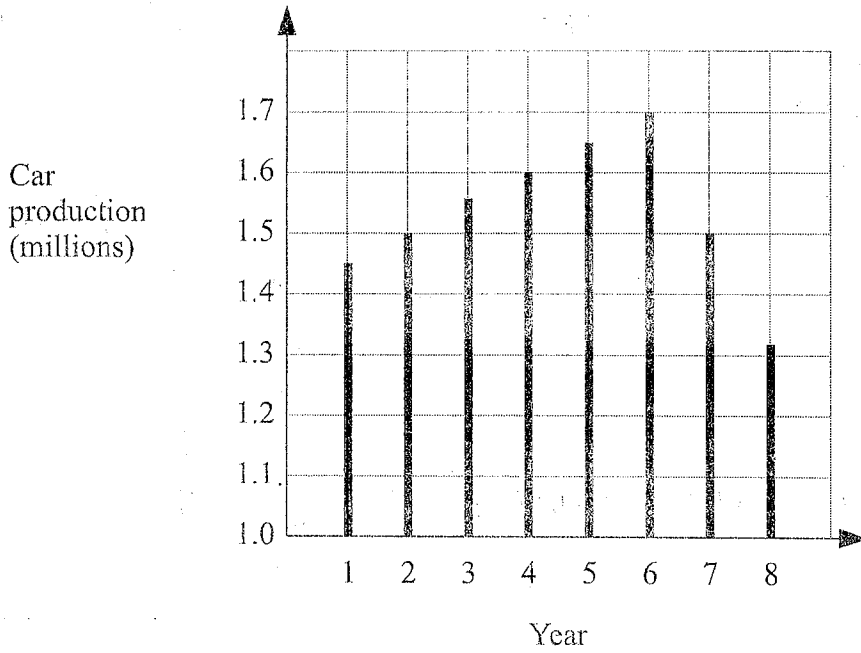

(a) For how many of these years was car production more than 1.6 million?

2  
(1)

(b) In which two years was car production the same?

2, 7  
(1)

(Total for Question 5 is 2 marks)

- 6 There are three cards in bag A and two cards in bag B.  
There is a letter on each card.

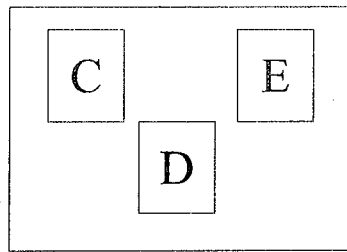

Bag A

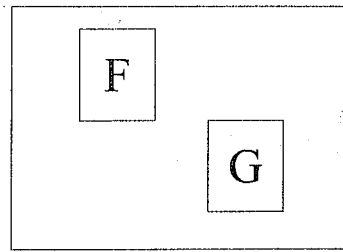

Bag B

Ali takes a card from bag A and then a card from bag B.

List all the possible outcomes.

CF, CG, DF, DG, EF, EG

(Total for Question 6 is 2 marks)

- 7 On Monday, Lucy pays for 2 plane tickets, 7 nights in a hotel and 2 theme park tickets.

	dollars		
each plane ticket	750	$\times 2$	$= 1500$
each night in a hotel	120	$\times 7$	$= 840$
each theme park ticket	125	$\times 2$	$= 250$

Show that Lucy pays more than 2500 dollars on Monday.

$$1500 + 840 + 250 = 2590$$

$$2590 > 2500$$

(Total for Question 7 is 3 marks)

8 (a) Solve  $\frac{y}{5} = 6$

$$y = 6 \times 5$$

$$y = \frac{30}{(1)}$$

(c) Solve  $2f - 9 = 12$

$$\begin{array}{r} 2f - 9 = 12 \\ + 9 \quad + 9 \end{array}$$

$$2f = 21$$

$$f = 10.5$$

$$f = \frac{10.5}{(2)}$$

(Total for Question 8 is 3 marks)

9 Here is part of a train timetable.

<b>Brighton</b>	07 22	07 29	07 32
<b>London</b>	08 50	08 32	08 48

Rosie gets to the station in Brighton at 07 15

(a) Work out how many minutes she has to wait until 07 22

$$22 - 15 = 7$$

$$\frac{7}{(1)} \text{ minutes}$$

(b) Work out how long it will take the 07 22 train to get to London.

$$\begin{array}{r} 07 \ 22 \\ + 1 \text{ hour} \\ 08 \ 22 \\ + 20 \text{ mins} \\ 08 \ 42 \\ + 8 \text{ mins} \quad 0850 \end{array}$$

$$\frac{1 \text{ hour } 28 \text{ minutes}}{(2)}$$

(Total for Question 9 is 3 marks)

- 10 Adam, Beth and Charlie share an amount of money in the ratio 6 : 7 : 8  
What fraction of the money does Charlie get?

$$6 + 7 + 8 = 21$$

$$\frac{8}{21}$$

(Total for Question 10 is 2 marks)

- 11 Cornflakes are sold in two sizes of box.

Size of box	Weight of cornflakes
small	540 g
large	720 g

Sophie buys 4 small boxes of cornflakes and some large boxes of cornflakes.  
In total she buys 4320 g of cornflakes.

Work out the number of large boxes of cornflakes Rae buys.

$$4 \times 540 = 2160$$

$$4320 - 2160 = 2160$$

$$\frac{2160}{720} = 3$$

3

(Total for Question 11 is 3 marks)

12 Here is a number machine.

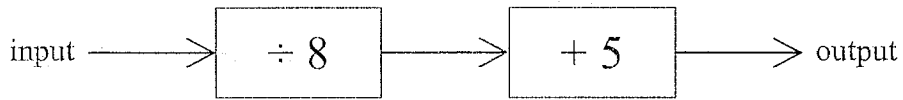

(a) Work out the output when the input is 48

$$48 \div 8 = 6 \quad 6 + 5 = 11$$

$$\begin{array}{r} 11 \\ \hline \end{array} \quad (1)$$

Here is a different number machine.  
The number machine is not complete.

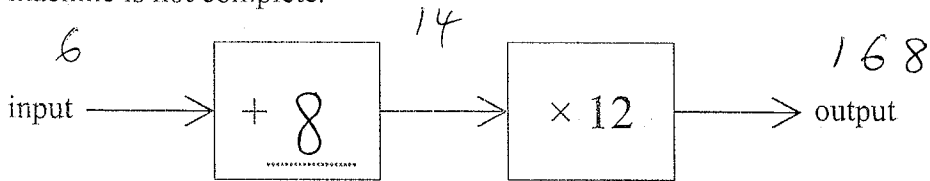

When the input is 6, the output is 168

(b) Complete the number machine.

(2)

$$168 \div 12 = 14$$

$$14 - 6 = 8$$

(Total for Question 12 is 3 marks)



13 (a) Complete the table of values for  $y = \frac{1}{2}x - 1$

x	-2	-1	0	1	2	3
y	-2	-1.5	-1	-0.5	0	0.5

(2)

(b) On the grid, draw the graph of  $y = \frac{1}{2}x - 1$  for values of x from -2 to 3.

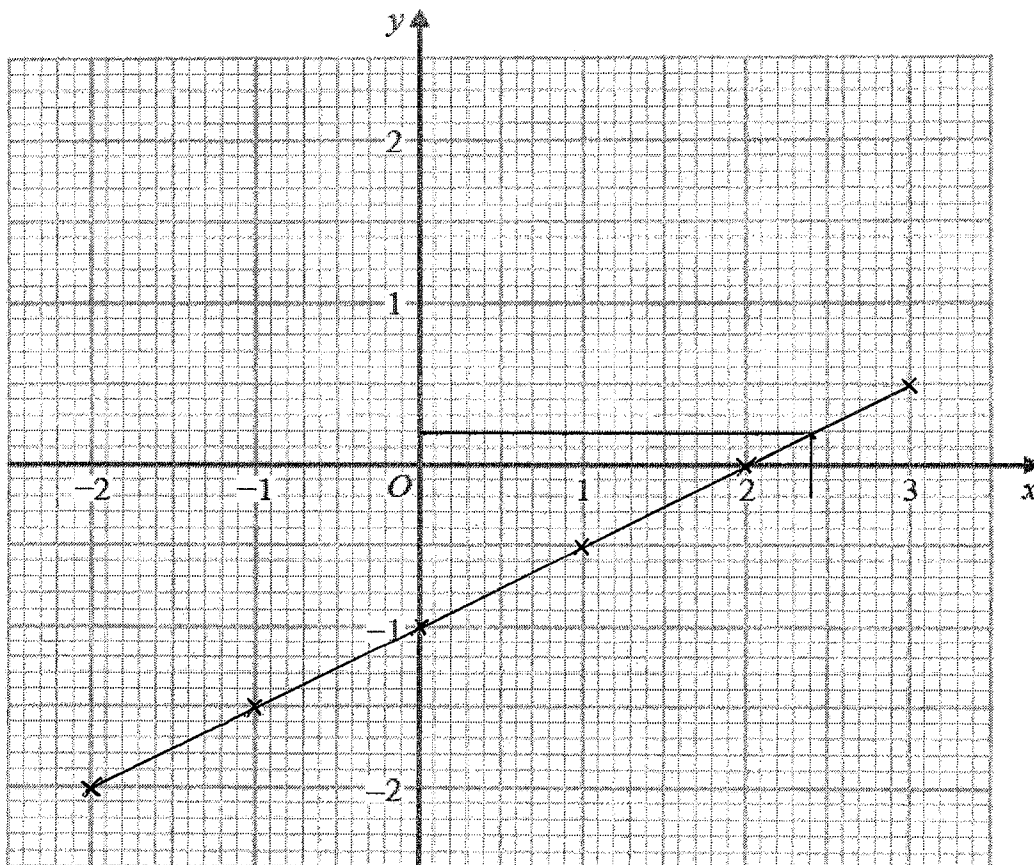

(2)

(c) Use your graph to find the value of x when  $y = 0.2$

$x =$  2.4

(1)

(Total for Question 13 is 5 marks)

- 14 A group of football fans were asked what their half time snack was. The table below gives information about their answers.

Snack	Number of fans		Degrees
burger	31	$\times 5$	155
pie	28	$\times 5$	140
hot dog	13	$\times 5$	65
	<u>72</u>	$\times 5$	<u>360</u>

Draw an accurate pie chart for this information.

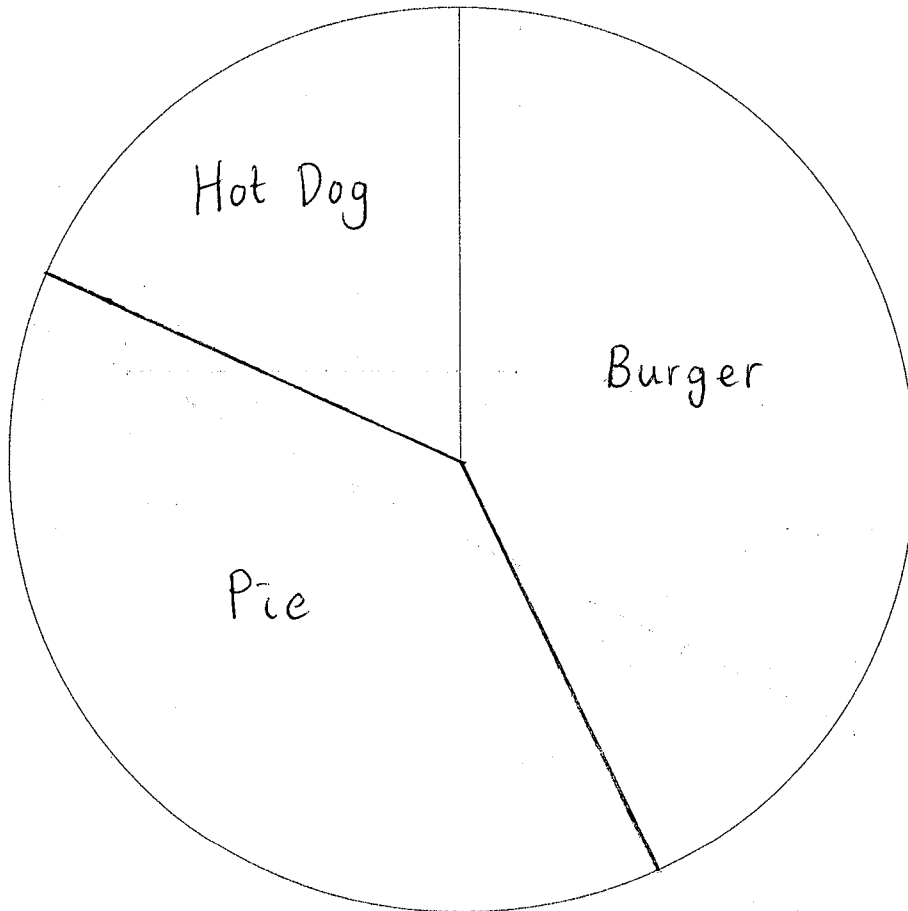

$$\frac{360}{72} = 5$$

(Total for Question 14 is 3 marks)

- 15 A shop sells compost in 40 litre bags and 50 litre bags.  
One day the shop had two special offers for compost.

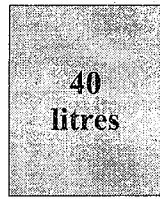

3 bags for £20

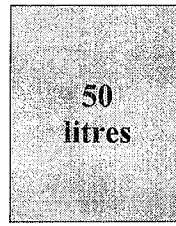

2 bags for £16

Which offer is the better value for money?  
You must show how you get your answer.

40 Litre bags

$$3 \times 40 = 120$$

120 litres for £20

$$\div 12$$

10 litres for £1.67

50 litre bags

$$50 \times 2 = 100$$

100 litres for £16

$$\div 10$$

10 litres for £1.60

50 litre bags

(Total for Question 15 is 3 marks)

- 16 There are 800 students at a school.  
Each student has either a school dinner or a packed lunch.

33% of the students have packed lunches.

$$0.33 \times 800 = 264$$

45% of the students are boys.

$$0.45 \times 800 = 360$$

55% of the boys have school dinners.

$$0.55 \times 360 = 198$$

How many girls have packed lunches?

You must show all your working.

	School Dinner	Packed Lunch	Total
Boys	198	162	360
Girls	338	102	440
Total	536	264	800

102

(Total for Question 16 is 4 marks)

17  $A$ ,  $B$  and  $C$  are three points on a map.

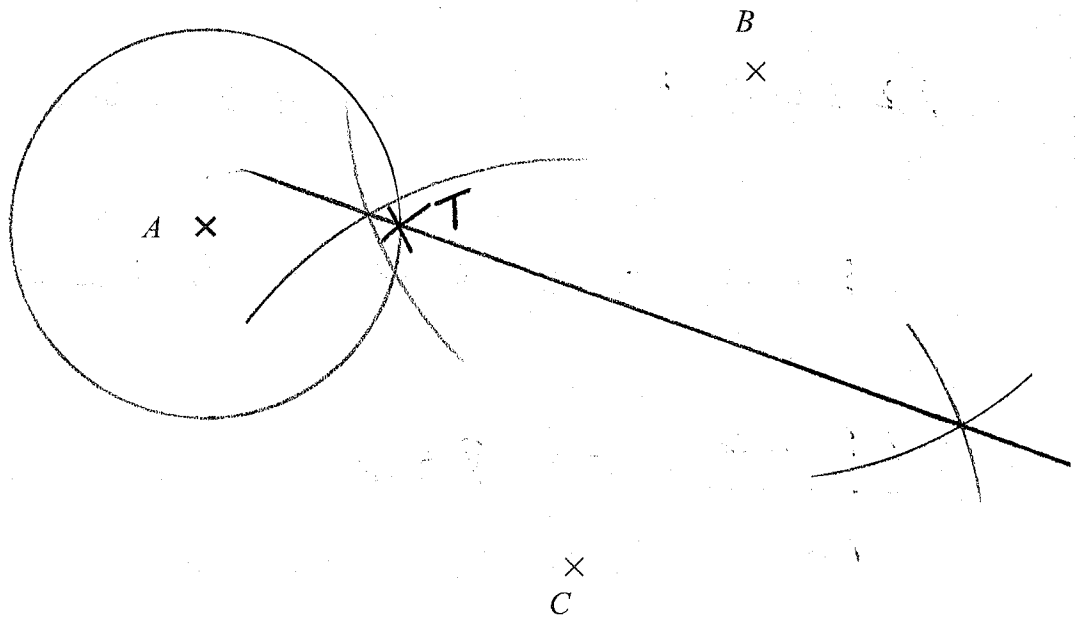

1 cm represents 100 metres.

Point  $T$  is 250 metres from point  $A$ .  $\frac{250}{100} = 2.5 \text{ cm}$   
Point  $T$  is equidistant from point  $B$  and point  $C$ .

On the map, show one of the possible positions for point  $T$ .

(Total for Question 17 is 3 marks)

18 Tyrone buys a boat.  
The cost of the boat is £12 100 plus VAT at 20%

Tyrone pays a deposit of £5000  
He pays the rest of the cost in 10 equal payments.

Work out the amount of each of the 10 payments.

$$12100 \times 1.2 = 14520$$

$$14520 - 5000 = 9520$$

$$\frac{9520}{10} = 952$$

£ 952

(Total for Question 18 is 4 marks)

19 Here are the heights, in centimetres, of 15 plants.

~~24~~ ~~22~~ ~~28~~ ~~22~~ ~~15~~ ~~31~~ ~~23~~ ~~34~~  
~~30~~ ~~25~~ ~~16~~ ~~30~~ ~~15~~ ~~22~~ ~~31~~

Draw a stem and leaf diagram for these heights.

1	5 5 6
2	2 2 <b>2</b> 3 4 5 8
3	0 0 1 1 4

Key:  $1/5 = 15\text{cm}$

(Total for Question 19 is 3 marks)

- 20 In April Damola drove 480 miles in his car.  
The car travelled 46.5 miles for each gallon of petrol used.

Petrol cost £1.38 per litre.  
1 gallon = 4.55 litres.

Work out the cost of the petrol the car used in April.

$$\frac{480}{46.5} = 10.32 \text{ gallons}$$

$$10.32 \times 4.55 = 46.97 \text{ litres}$$

$$46.97 \times 1.38 = £64.82$$

£ 64.82

(Total for Question 20 is 4 marks)



21  $A = 2^3 \times 3^2 \times 5$

$B = 2^2 \times 3^3 \times 5$

Write down the highest common factor (HCF) of A and B

$$2^2 \times 3^2 \times 5 = 180$$

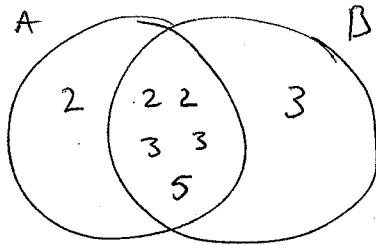

180

(Total for Question 21 is 1 mark)

- 22 Verity buys 12 bottles of apple juice for a total cost of £15  
Verity sells all 12 bottles at £1.75 each bottle.

Work out Verity's percentage profit.

$$\text{Profit} = \frac{\text{change}}{\text{original}} \times 100$$

$$12 \times 1.75 = 21$$

$$\text{Profit} = 21 - 15 = 6$$

$$\% \text{ Profit} = \frac{6}{15} \times 100$$

$$= 40$$

40%

(Total for Question 22 is 3 marks)

23 The table shows the populations of five countries.

Country	Population
India	$1.4 \times 10^9$
Turkey	$8.4 \times 10^7$
Denmark	$5.8 \times 10^6$
Estonia	$1.3 \times 10^6$
Iceland	$3.4 \times 10^5$

- (a) Work out the difference between the population of India and the population of Turkey.  
Give your answer in standard form.

$$1.4 \times 10^9 - 8.4 \times 10^7 = 1316000000$$

$$\frac{1.316 \times 10^9}{(2)}$$

Given that

$$\text{population of Iceland} = \frac{1}{k} \times \text{population of Denmark}$$

- (b) Work out the value of  $k$ .  
Give your answer correct to the nearest whole number.

$$\frac{5.8 \times 10^6}{3.4 \times 10^5} = 17 \text{ (nearest whole no.)}$$

$$k = \frac{17}{(2)}$$

(Total for Question 23 is 4 marks)

24 The diagram shows the front of a wooden door with a semicircular glass window.

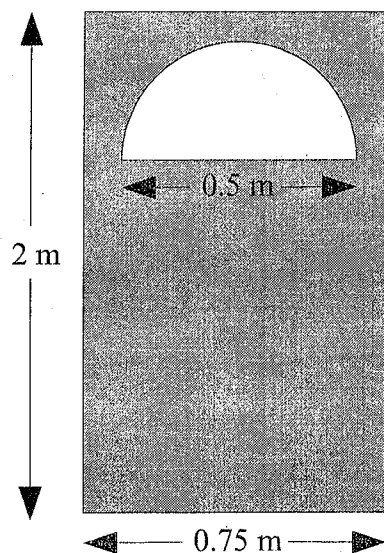

$$r = 0.25$$

Julie wants to apply 2 coats of wood varnish to the front of the door, shown shaded in the diagram.

250 millilitres of wood varnish covers  $4 \text{ m}^2$  of the wood.

Work out how many millilitres of wood varnish Julie will need.  
Give your answer correct to the nearest millilitre.

$$\text{Area of rectangle} = 2 \times 0.75 = 1.5 \text{ m}^2$$

$$\text{Area of semi circle} = \frac{\pi (0.25)^2}{2} = 0.098 \text{ m}^2$$

$$\begin{aligned} \text{Area of wood} &= 1.5 - 0.098 \\ &= 1.40 \text{ m}^2 \end{aligned}$$

$$2 \text{ coats} \quad 1.40 \times 2 = 2.80 \text{ m}^2$$

$$\begin{array}{l} 250 \text{ ml for } 4 \text{ m}^2 \\ \div 4 \quad \quad \quad \div 4 \end{array}$$

$$62.5 \text{ ml per m}^2$$

$$2.80 \times 62.5 = 175$$

$$\underline{175} \text{ millilitres}$$

(Total for Question 24 is 5 marks)

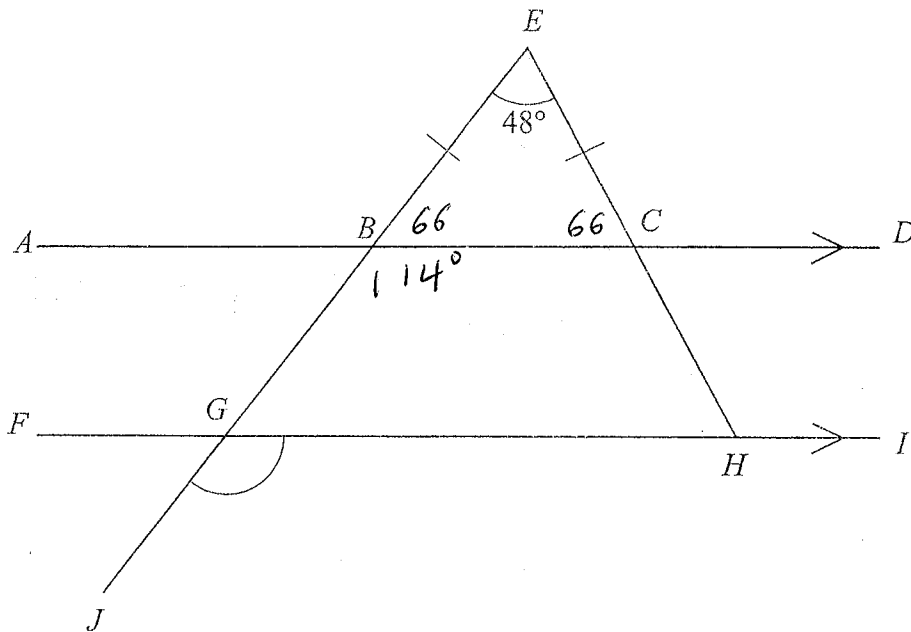

$ABCD$  and  $FGHI$  are parallel straight lines.

$EBGJ$  and  $ECH$  are straight lines.

$BE = CE$

Angle  $BEC = 48^\circ$

Work out the size of angle  $JGH$ .

Give a reason for each stage of your working.

$$\frac{180 - 48}{2} = 66^\circ$$

Angles at the base of an isosceles triangle are equal ( $EBC$ )

$$180 - 66 = 114^\circ$$

Angles on a straight line add to  $180^\circ$  ( $GBC$ )

$$\angle JGH = 114^\circ$$

Corresponding angles

114°

(Total for Question 25 is 5 marks)

26  $ABCD$  is a trapezium.

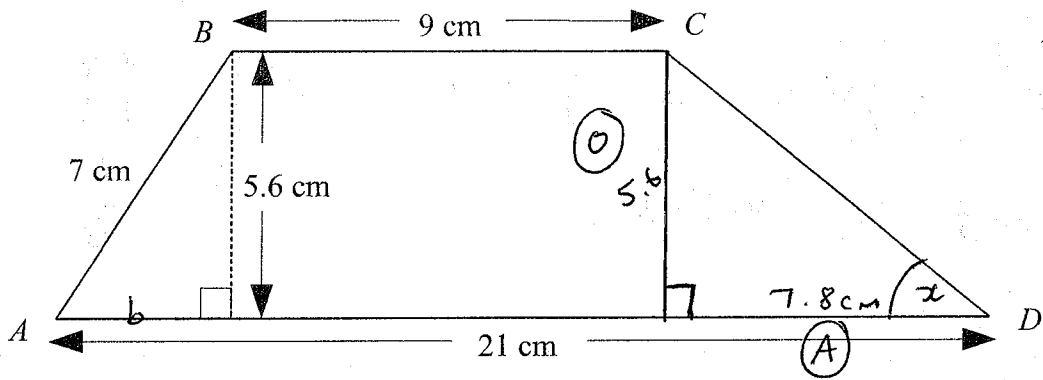

Work out the size of angle  $CDA$ .  
Give your answer correct to 1 decimal place.

$$a^2 + b^2 = c^2$$

$$5.6^2 + b^2 = 7^2$$

$$b^2 = 7^2 - 5.6^2$$

$$b^2 = 17.64$$

$$b = \sqrt{17.64}$$

$$= 4.2 \text{ cm}$$

$$21 - 9 - 4.2 = 7.8 \text{ cm}$$

$$\tan x = \frac{5.6}{7.8}$$

$$x = \tan^{-1} \left( \frac{5.6}{7.8} \right)$$

$$= \underline{\underline{35.7^\circ}}$$

~~SOH CAH TOA~~

.....  
35.7 °

(Total for Question 26 is 5 marks)

27 Solve  $x^2 - 11x + 24 = 0$

$$(x - 3)(x - 8) = 0$$

$$x = 3$$

$$x = 8$$

	24
1	24
2	12
3	8
4	6

$$x = 3 \text{ or } x = 8$$

(Total for Question 27 is 3 marks)

**TOTAL FOR PAPER IS 80 MARKS**